

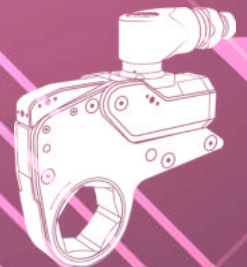

Atlas Copco

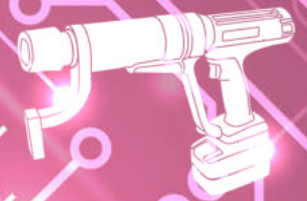

Bolting Solutions

Innovative Bolt Tensioning, Hydraulic Torque and Continuous Rotation tools for industrial applications.

Taking the smart factory to the field.

Smart Connected Bolting

Taking the Smart Factory to the Field.



Supporting the energy transition

The energy sector is undergoing huge change. Not only is there a transition from fossil fuel sources to clean renewable sources, but all energy sector operations need to increase productivity and reduced costs to remain competitive. This is driving demand for smart bolting solutions that can increase operational efficiency, in areas such as faster process times, less bolted joint failures, and optimized service costs.

Here at Atlas Copco we are developing innovative new solutions that are enabling Industry 4.0 to be applied not only in the factory, but also in the field.

Why Smart Connected Bolting is important for you

If the process control and documentation capability used in manufacturing facilities today were to be deployed in the operations and maintenance environment, this would have significant positive impact for OEM's, contractors and the energy industry as a whole relating to higher quality delivered work, cost reduction, and improved operational efficiency.

This was not possible in the past, however the new availability of mobile connectivity, cloud solutions and smart devices are enablers that make this very much a reality today. The availability of these solutions now make it possible to take the "smart factory" into the field.

In order to have a truly connected and efficient system it is critical that all bolting technologies (hydraulic torque, bolt tensioning, continuous rotation) have one common user interface, both for operational process control and analysis and traceability of data. This is what we call Smart Connected Bolting.



Scan me to view the
webpage!

Start your transformation!

Switch to smart tooling today.



Smart tools
with sensors to
reduce errors

Digital data to enable
better and faster
decision making

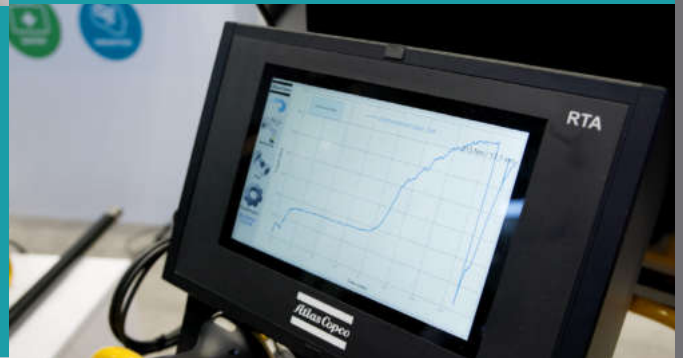

Any location
in the factory
and in the field



"The energy industry is becoming more global and more competitive every day. Larger bolts, in more extreme environments and with longer product life cycles means there is a need for new bolting solutions that support the goal of maintenance free bolted assembly.

To address these demands, the implementation of smart factory technology in the field based environment is a critical path to take that will ensure the best quality products are manufactured, installed and operated for the full product life cycle with reductions in both risk and cost." - Calum Urquhart - Global Business Manager, Energy

Reach out to your local Atlas Copco sales representative, and find out how Smart Bolting Solutions can improve your processes.

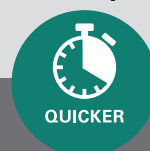

Bolting tools

For critical bolting applications

You now have one reliable partner that gives you access to a complete line of bolt tightening tools to boost your productivity and minimize downtime. Whether using our custom-designed hydraulic bolt tensioners, our robust and accurate hydraulic torque wrenches, or our industry-leading battery, electric or pneumatic nutrunners, we bring the best product and support available to you.

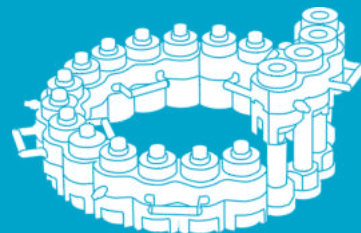
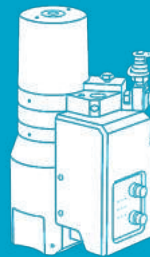
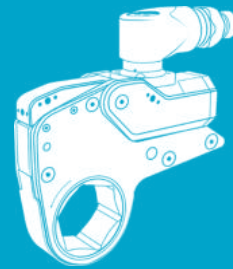
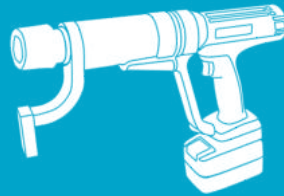

We are passionate about bringing solutions to our customers' bolt tightening challenges. This is why we are in this business. We believe in tight connections through technology and people.

Tight connections

For your applications

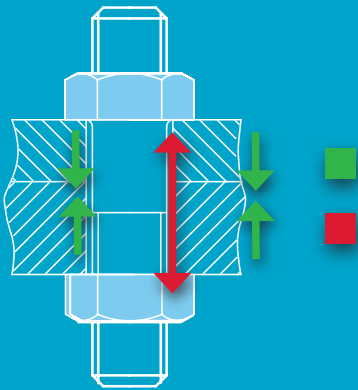

Torque and Tension are two distinct ways to achieve the same result: create the appropriate clamping force for the joint or connection. To do this, the bolt has to stretch, while a nut holds the load and thereby creating the desired clamp force. Atlas Copco offers a comprehensive product range of torque and tension tools, to work on critical bolting applications.

Torque

Using torque tools, such as nutrunners or hydraulic torque wrenches, you turn the nut. As the nut turns, it stretches the stud. The torque setting for the tool translates into load on the connection. When the tools are used following the appropriate specifications for lubrication, coating and other factors, a desired clamp force can be produced.

Tension

With tensioners, the action is not directly on the nut, rather tension is applied directly to the stud in order to produce stretch. Once the prestretch is achieved, the nut can be tightened. Once the pressure is released the nut holds the load on the bolt. This produces the clamp force. Multiple tensioners can be used together to provide even load when tightening. Hydraulic bolt tensioners have a footprint and thread height requirement.

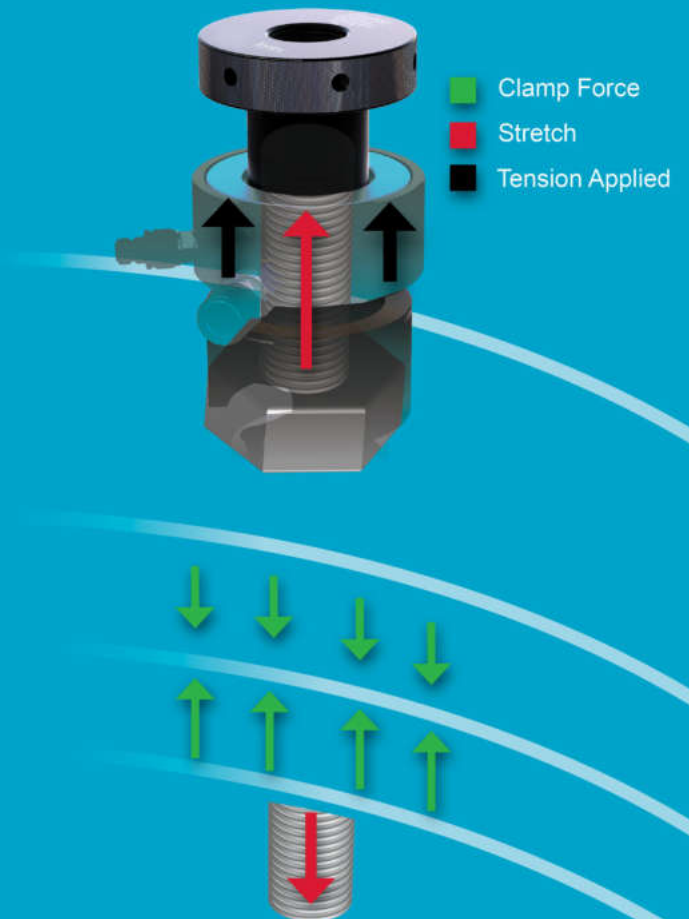
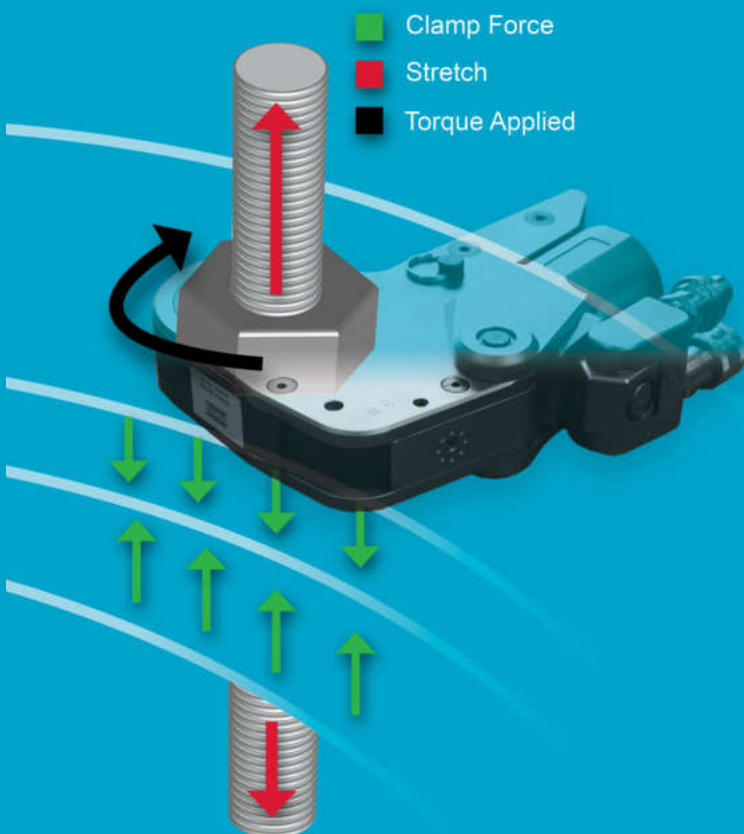

Bolting Solutions tool type

Introduction



Manual Torque Wrenches

9

Manual torquing at it's best.

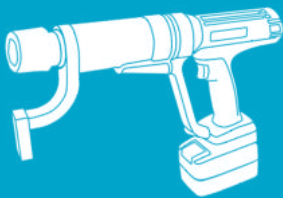

Continuous Rotation

13

In this section you will find all continuous rotation tools including; battery nutrunners, electric nutrunners and pneumatic nutrunners covering a range of applications.

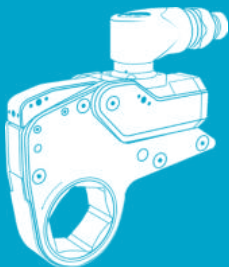

Hydraulic Torque Wrenches

43

Available in standard or low profile models, this is the cornerstone for high torque applications.



Hydraulic Bolt Tensioning

95

Available in standard or custom models, to suit any application. Works with hand, air or electrical powerpack

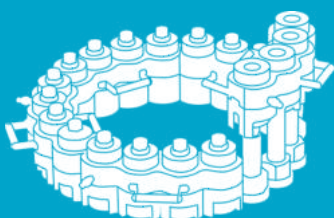

Customized Bolting Solutions

123

Here at Atlas Copco we have the ability to design, manufacture and assemble bespoke customized bolting solutions for any application.

Table of Contents

Manual wrench series	9
Pro ACTW Manual Torque Wrenches	
Continuous rotation	13
SRBHA - Smart Battery Nutrunner	
Tensor Revo HA - High Torque Electric Nutrunner	
Pneumatic nutrunners	27
RTP - High Torque Pneumatic Nutrunner	
LTP & LMP - Pneumatic Nutrunners.	
Hydraulic torque	43
TF - Square Drive Hydraulic Torque Wrench	
RT - Square Drive Hydraulic Torque Wrench	
TFX - Direct Fit Hydraulic Torque Wrench	
RTA - Smart Hydraulic Wrench system	
SP700 - Smart Torque Powerpack	
Hydraulic Torque Powerpack	
Hydraulic bolt tensioning	95
STS - Smart Tensioning System	
CTST - Topside Tensioner	
Airbac - Auto Retract Tensioner	
Compact 8 - Subsea Tensioner	
WTB - Wind turbine Bolt Tensioner	
SP1500 - Smart Tensioning Powerpack	
Bolt tensioning Powerpack	
Hydraulic nuts	121
Customized bolt tensioners	123
Flange spreaders	129
Nut splitters	131
Software	135



PRO ACTW Torque Wrenches

Manual torquing at its best

Atlas Copco PRO Torque Wrenches are manufactured to meet global standards of accuracy for customer torquing needs.

The series can be used as a stand-alone product or together with Atlas Copco Impact Wrenches to ensure that the correct torque has been applied for non-critical applications.

All of these click type torque wrenches come with a quality ratchet head that provides a distinctive and audible click sound. The series comes in different models covering a torque range of 5-1000 Nm. The series provides a $\pm 4\%$ accuracy based on the EN ISO 6789-1:2017 standard.



Benefits

- Easy to reach cramped spaces
- Durable aluminium handle for easy operator handling
- Audible click sound for real-time operator feedback
- Up to 25,000 cycles

Features

 Compact design

 Light weight

 Operator feedback

 High accuracy

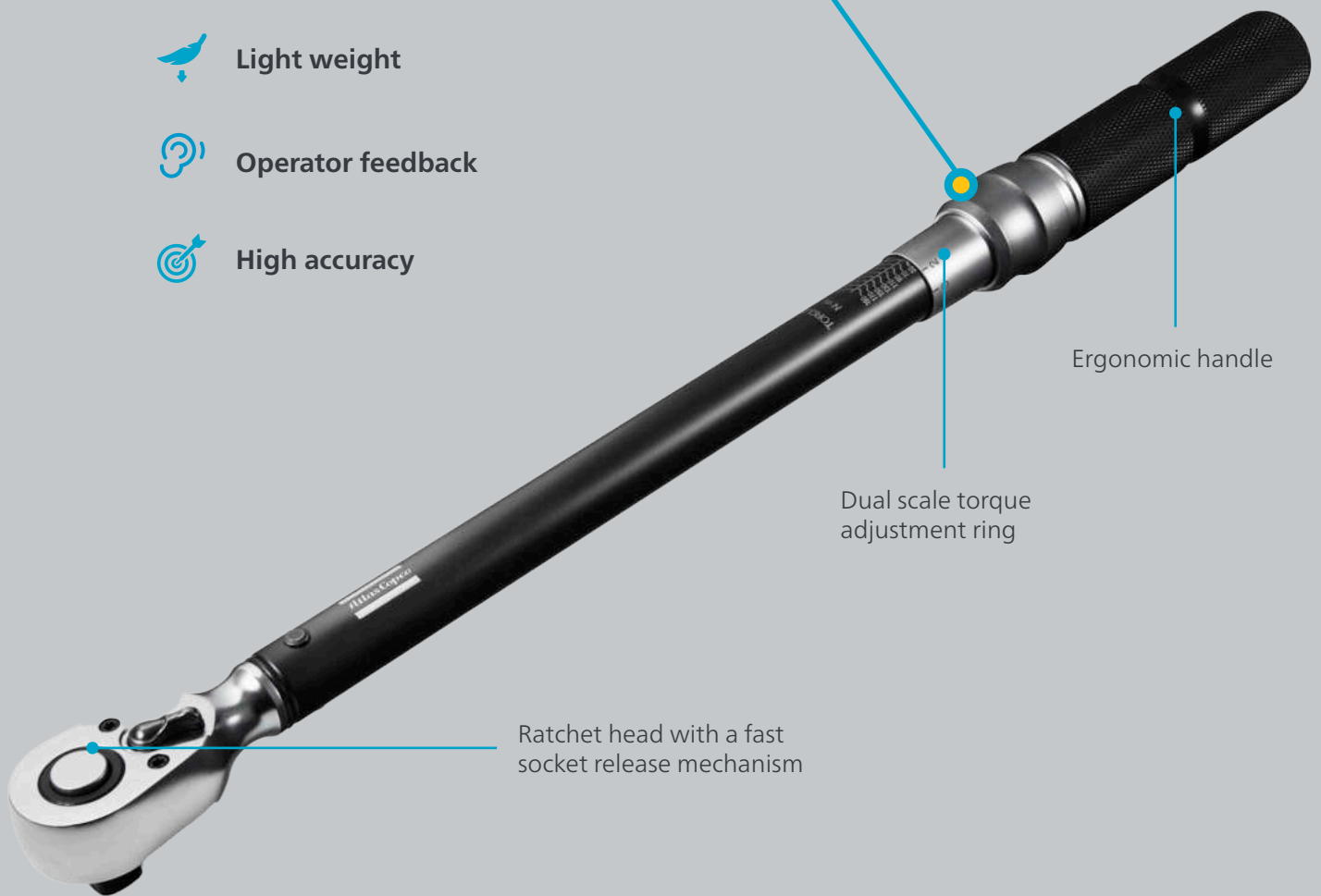

Applications



Rolling Stock MRO



Oil & Gas

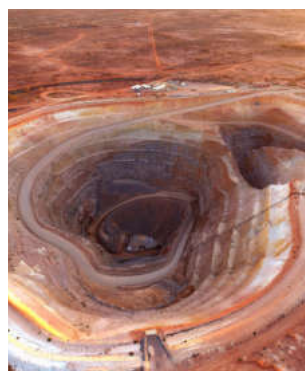

Mining MRO

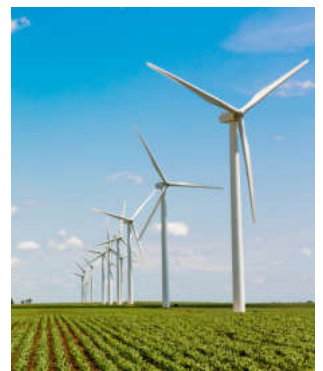

Wind

Technical data

Model	Drive square [in]	Torque range [Ft lb]	Torque range [Nm]	Weight [kg]	Weight [lb]	Length [mm]	Part Number
ACTW05	1/4"	44-221 (in lb)	5-25	0.4	0.8	248	8434 0300 01
ACTW20	3/8"	15-74	20-100	1.2	2.6	408	8434 0300 02
ACTW40	1/2"	30-148	40-200	1.6	3.5	519	8434 0300 03
ACTW150	3/4"	110-553	150-750	5.72	12.5	1124	8434 0300 04
ACTW200	1"	148-738	200-1000	6.52	14.3	1224	8434 0300 05

Accessories



WS1001



WS1002



WS1003

Model	Square drive size [in]	Socket type	Number of sockets	Sockets included [mm]	Ordering No.
PRO WS1001	3/8"	Metric impact socket	13	7, 8, 9, 10, 11, 12, 13, 14, 15, 16, 17, 18, 19	4112 0607 91
PRO WS1002	1/2"	Metric impact socket	14	10, 11, 12, 13, 14, 15, 16, 17, 18, 19, 21, 22, 26, 27	4112 0607 92
PRO WS1003	1/2"	Metric deep impact socket	14	10, 11, 12, 13, 14, 15, 16, 17, 18, 19, 21, 22, 26, 27	4112 0607 93



PRO website



PRO videos on Youtube



PRO catalogue

Scan the codes to discover more about PRO

Continuous Rotation





OK

1425 Nm
S&G: 1425

Atlas Copco

1001450000
1001450000
1001450000

SRB HA

Smart high torque battery tool



Scan me to view the webpage!

Improve your operations with a high-productivity intelligent battery tool for your critical applications.

Atlas Copco has been a preferred supplier to the global manufacturing industry for decades. We were the first company to develop and introduce smart electric tools into the factories more than 30 years ago. With our new battery range, we are applying our knowledge and experience to take the smart factory to the field





SRBHA smart high torque battery tool



Digital

The digital version is our basic version where the tool is ready to go straight out of the box. Use the buttons to set the desired torque and start tightening. No possibility to save the tightening data.

Smart

Pre-program up to 10 presets and 10 batches to control your process. The target can be either torque or torque plus angle. Easily shift between the settings and once the job is done, it is simple to download the data for traceability. No additional software or program is needed.

Connected

Connect your battery tool to the Power Focus 6000 controller, which takes your productivity, quality and connectivity to entirely new levels. The PF6000 controller is easily integrated into overlying systems for live data feed and analysis.



Feature / Model

Digital

Smart

Connected

Feature / Model	Digital	Smart	Connected
Dual Trigger	●	●	●
Socket Release	●	●	●
Guiding LED Feedback	●	●	●
Torque Transducer	●	●	●
Permanent Magnet Motor	●	●	●
HMI Display	●	●	●
Internal wifi Server for Data Collection		●	●
Presets (10)		●	●
Batch Mode (10)		●	●
Angle Monitoring		●	●
Torque + Angle Strategy		●	●
Torque Tolerances		●	●
Live Data Collection			●
Operator guidance			●
SQS Configuration			●
PF6000 Configuration			●

SRBHA tool features



Operator Control & Feedback

- Display with 3 buttons
- Pset Selection / Quick Torque
- Easy interface for the operator

Torque Range

- Four models :
1300/2400/3400/4000 Nm

IP41 Protection

- Ingress Protection

Function Button

- Customisable button / Reverse

Dual Trigger

- Both triggers need to be pressed
- Minimize risk of injury

Ergonomics

- Well balanced
- D handle for robustness and safety

Multi-functional LED

- White spotlight for dark areas
- OK/NOK feedback for operator

Connects direct to any mobile device

- No app needed
- No additional software
- No wifi network needed

Battery, Drive & Performance

- 36 V smart battery
- High performance motor
- Built in torque transducer and angle sensor



SRBHA information and ordering numbers

Model	Torque range [Nm]	Speed [rpm]	Weight [kg]	Spline / Wave	Sq. drive	Gear dia [mm]	Length [mm]	Tool Only Ordning No.	Tool complete Kit Ordning No.
ETP SRB81-200-20	60-200	139	3.63	S 3	3/4"	54	338	8433250111	8433250191
ETP SRB81-200-20-D	60-200	139	3.63	S 3	3/4"	54	338	8433250101	8433250181
ETP SRB81-300-20	90-300	103	3.63	S 3	3/4"	54	338	8433250211	8433250291
ETP SRB81-300-20-D	90-300	103	3.63	S 3	3/4"	54	338	8433250201	8433250281
ETP SRB81-500-20	150-500	65	4.56	S 4	3/4"	67	368	8433250311	8433250391
ETP SRB81-500-20-D	150-500	65	4.56	S 4	3/4"	67	368	8433250301	8433250381
ETP SRB81-750-25	225-750	46	4.87	S 4	1"	67	387	8433250411	8433250491
ETP SRB81-750-25-D	225-750	46	4.87	S 4	1"	67	387	8433250401	8433250481
ETP SRB81-950-25	285-950	35	5.04	S 5	1"	67	398	8433259511	8433259591
ETP SRB81-950-25-D	285-950	35	5.04	S 5	1"	67	398	8433259501	8433259581
ETP SRB81-1300-20-HA	390-1300	23	4.7	W 40	3/4"	63	384	8433250611	8433250691
ETP SRB81-1300-20-HA-D	390-1300	23	4.7	W 40	3/4"	63	384	8433250601	8433250681
ETP SRB81-2400-25-HA	720-2400	11	6	W 47	1"	67	431	8433250711	8433250791
ETP SRB81-2400-25-HA-D	720-2400	11	6	W 47	1"	67	431	8433250701	8433250781
ETP SRB81-3400-25-HA	1020-3400	7	7.7	W 60	1"	82	444	8433250811	8433250891
ETP SRB81-3400-25-HA-D	1020-3400	7	7.7	W 60	1"	82	444	8433250801	8433250881
ETP SRB81-4000-25-HA	1200-4000	5	7.7	W 60	1"	82	444	8433250811	8433250891
ETP SRB81-4000-25-HA-D	1200-4000	5	7.7	W 60	1"	82	444	8433250801	8433250881
ETP SRB81-4500-HA	1350-4500	3.6	7.9	W 60	1,5"	82	444	8433250911	8433250991
ETP SRB81-4500-HA-D	1350-4500	3.6	7.9	W 60	1,5"	82	444	8433250901	8433250981
ETP SRB81-6500-HA	1950-6500	2.6	9.9	W 72	1,5"	102	481	8433251011	8433251091
ETP SRB81-6500-HA-D	1950-6500	2.6	9.9	W 72	1,5"	102	481	8433251001	8433251081

D = Digital

Kit = Tool, battery charger, S-Type reaction bar, 2 batteries in a case

Weight is tool only

SRBHA batteries and accessories

Battery/Charger	Ordering. No.
Battery Li-Ion 36V 2.6 Ah	4211 6030 86
Multicharger 18-36V	4211 6083 84
Protective cover 36V	4211 6090 36
Tool protective cover (included with tool)	4216 4271 02

Accessories	Ordering. No.			
	A. Steel Bar	B. S-type	C. Sliding drive	D. Square bracket
SRB HA 1300	4210 4757 90	4210 4480 90	4210 4752 90	4210 4758 90
SRB HA 2400	4210 4757 93	4210 4480 94	4210 4752 93	4210 4758 93
SRB HA 3400/4000	4210 4757 85	4210 4480 85	4210 4752 85	4210 4758 85



Tensor Revo HA

Electric transducerized nutrunner



Scan me to view the webpage!

Increase productivity with our electric nutrunner Tensor Revo HA

Atlas Copco known for their high performing electric tools, and it's no different with the Tensor Revo HA. The Tensor Revo HA is the most productive high torque bolting tool in the market today, with a tightening speed 3 times faster than competitors, enabling huge time savings in operation. When combined with the Power Focus XC, you get the ultimate electric nutrunner.





Tensor Revo HA





Portable controller. Controlled by the Power Focus XC, giving you the best experience when working in the field.

Quality. Unique transducerized tool with swivel offers quality of tightenings and traceability.

Slim gears offer highest accessibility to application. 5 models of tools from 390 to 8000 Nm.

Handle angle adjusting joint.

Two Hand start. The Revo HA is designed with safety and ergonomics in mind. The two hand start ensures operator safety during tightening operation. Better ergonomics and handling with adjustable handle.

360° swivel reaction bar. Offers flexibility while working on different applications. Wide range of light weight reaction bars are available.

Led Lights provide instant and clear feedback to the operator.

Common controller. Controlled by the Power Focus 6000, the common touch screen controller for all Tensor tools.

Tensor Revo HA electric transducerized nutrunner

Traditional air and hydraulic tools have problems with noise, vibration and unproductive operation. Also, on most tools the operator cannot see the tightening result. This leads to unnecessary investments in additional tools.

Easy accessibility

With usability in focus, the Revo HA is designed with a slim gearbox and compact reaction bars with relatively low weight. It's also equipped with a socket release function that releases the socket and reaction bar from the joint after tightening is done.

Process quality

The Revo HA is the first ever swiveling transducerized tool in this segment. It uses traceability, angle control and monitoring to assure perfect joint quality.

Faster tightening process

These high torque models can operate at comparatively high speeds. With multi torque setting buttons and operator feedback on the display the tightening process is shortened.

Safe and ergonomic

Two-handed start trigger makes it safer to operate. With the tool weight balanced out in two hands operator fatigue is reduced. The low vibration and noise level provides a much sounder and comfortable working environment. The controller case enables easy transport between stations and tasks.

The best just got better

Introducing the Power Focus XC to further enhance the Tensor Revo HA



Alone, the Electric Nutrunner Tensor Revo HA is the quickest high torque tool on the market, with a tightening speed up to 3 times fast than our competitors. Now with the PFXC torque controller, the best just got better.

Designed with simplicity, scan with your phone and see everything in a instant. With no WiFi required you can logon to the controller with any WiFi device to: see tightening results, set Psets including the tightening strategy, speed and target torque. Also, with the ability to send the information to anyone in the world instantly!

The Power Focus XC combined with any Tensor Revo tool supplies you with the ultimate Smart Electric Nutrunner system.

Model	Length mm	Weight kg	Weight lb	Ordering No.
PFXC Drive Unit with License	440	11.2	24.69	8436 1800 50



Tool ordering numbers

Model	Square Drive	Torque range		Speed rpm	Weight		Length mm	Ordering No.
		Nm	ft lb		kg	lb		
ETP ST101-200-20-F	3/4"	60-200	44-148	396	5,2	114.64	303	8433230202
ETP ST101-300-20-F	3/4"	90-300	66-222	293	5,2	114.64	303	8433230302
ETP ST101-500-20-F	3/4"	150-500	110-370	186	5,9	131.55	334	8433230502
ETP ST101-750-25-F	1"	225-750	165-550	132	6,2	138.24	353	8433230752
ETP ST101-1000-25-F	1"	300-1000	222-738	99	6,4	142.7	364	8433231002
ETP ST101-1500-25-F	1"	450-1500	332-1106	47	8,8	196.22	402	8433232152
ETP ST101-2000-38-F	1 1/2"	600-2000	442-1475	38	11,5	256.42	454	8433232202
ETP ST101-3000-38-F	1 1/2"	900-3000	665-2212	24	14,8	330.01	476	8433232302
ETP ST101-4000-38-F	1 1/2"	1200-4000	885-2950	20	15	334.47	481	8433232402
ETP ST101-1300-20-F-HA	3/4"	390-1300	287-958	65	6,4	142.7	348	8433231303
ETP ST101-2400-25-F-HA	1"	720-2400	530-1770	31	7,5	167.23	400	8433232603
ETP ST101-3400-25-F-HA	1"	1020-3400	752-2505	23	9,1	202.91	412	8433233403
ETP ST101-4000-25-F-HA-2	1"	1200-4000	885-2950	20	9,1	202.91	412	8433234003
ETP ST101-5500-38-F-HA	1 1/2"	1650-5500	1216-4055	17	13,2	294.33	452	8433232503
ETP ST101-6500-38-F-HA	1 1/2"	1950-6500	1438-4795	12	13,2	294.33	452	8433232703
ETP ST101-8000-38-F-HA	1 1/2"	2400-8000	1770-5900	10	13,2	294.33	452	8433232803

Torque controllers

Controller hardware & Software	Ordering No.
PFXC Drive Unite with License	8436 1800 50
Power Focus 6000	8436 1800 02
IAM Process Control	8436 0910 40
IAM Process Control 2 VS	8436 0910 42
IAM Process Control 3 VS	8436 0910 43
IAM Process Control 4 VS	8436 0910 44
IAM Process Control 5 VS	8436 0910 45
IAM Process Control 6 VS	8436 0910 46
IAM Process Plus Control	8436 0910 50
IAM Process Plus Control 2 VS	8436 0910 52
IAM Process Plus Control 3 VS	8436 0910 53
IAM Process Plus Control 4 VS	8436 0910 54
IAM Process Plus Control 5 VS	8436 0910 55



Model	Ordering No.
Controller carry case IP67 class	8433 2305 10
Controller mounting stand	4222 1736 04
Compact cooling fan module	4222 1599 80
Controller IP54 kit	4222 1769 90

* Power Focus XC comes with IAM license preloaded. With PF6000 it needs to be purchased separately.

Accessories

Model	Ordering No.
Revo HA1300/2600 case	8433 2305 11
Revo HA4000 case	8433 2305 12
Revo HA5800/8000 case	8433 2305 13
Tool protective cover (included)	4220 4299 00
Support handle (included)	4220 4001 83
Adjustable operator handle with trigger	4220 4522 82
Fan module for tool	4220 4417 90
Quick change socket release kit 3/4"	4210 3476 80
Quick change socket release kit 1"	4210 3524 80
ST barcode scanner	8433 0615 50

Model	Ordering No.
Protective cover for ST scanner	4220 2762 10
Tool cables - Power Focus 6000	
ST Cable, 5m	4220 4375 05
ST Cable 7m	4220 4375 07
ST Cable, 10m	4220 4375 10
ST Cable, 15m	4220 4375 15
Cable protection	4220 2977 90

Reaction bars and suspension yokes (not included)

Tool model	A. Steel Bar	B. S-type	C. Sliding Drive	D. Square bracket	E. Swivelling suspension yoke
Revo HA 1300	4210 4757 90	4210 4480 90	4210 4752 90	4210 4758 90	4210 3088 83
Revo HA 2400	4210 4757 93	4210 4480 94	4210 4752 93	4210 4758 93	4210 3088 82
Revo HA 4000	4210 4757 91	4210 4480 93	4210 4752 91	4210 4758 91	4210 3088 81
6500/8000	4210 4757 92	4210 4480 92	4210 4752 92	4210 4758 92	4220 4075 91*

* Refer ServAid for accessories selection

Error proofing modules	Ordering No.
Stacklight ESL04	8433 0570 13
Operator panel advanced	8433 0565 00
Selector, large sockets	8433 0610 44



Pneumatic nutrunners



Slim, lightweight pneumatic nutrunners which work on multiple applications

The light weight of the pneumatic nutrunners will surprise you, yet their high speed motor has the power you need to tighten big bolts. A robust, lightweight reaction bar absorbs the torque. Noise and vibration levels are lower than in traditional impact wrenches.



HR2S
No. A6511002
RTP 4100 HR2S
Max torque 4100 Nm
Free Speed 10 rpm
Pmax 6,0 bar / 87 psi max

RTP

High torque pneumatic nutrunner



The Pistol Nutrunner RTP is designed for flange-related and other bolting applications. The lightweight nutrunner helps increase productivity where the job includes loosening or tightening heavy duty bolts. The tool's slim gear-pack gives effortless access to bolts in cramped spaces making it a valuable tool for reman (remanufacturing) maintenance, repair and overhaul operations.

Whatever your industry, if your operations include loosening or tightening heavy duty bolts, Atlas Copco's slim, lightweight RTP pneumatic nutrunner can help increase your productivity.

Fast and accurate

Well proven Atlas Copco air motor.

Swivelling gear pack

The lightweight of the RTP nutrunner will surprise you, yet its high speed motor has the power you need to tighten big bolts.

Excellent accessibility, high accuracy

Among the smallest on the market, the RTP's slim gearpack gives you effortless access to bolts in cramped spaces. Tightening accuracy and repeatability are high.

Reaction bars

Absorbs reaction force. Different bars are available.



RTP Pneumatic nutrunners



Among the smallest on the market, the RTP's slim gearpack gives you effortless access to bolts in cramped spaces. Tightening accuracy and repeatability are high.

Plug & play! Simply connect the RTP to your air line and start working with it. The torque output of the RTP is adjusted with an Atlas Copco FRL air pressure unit, helping to prolong the lifetime and torque accuracy of the tool. The tool's exchangeable drive simplifies maintenance and cuts repair costs.

RTP Nutrunner kit

Model	Bolt size mm	Square drive in	Min torque at 1.5 bar Nm	Max torque at 6.3 bar Nm	Free speed r/min	Weight ^a kg	Length mm	CS distance mm	Air consumption at free speed l/s	Rec. hose size mm	Air inlet thread in	Ordering No.
RTP1300-HR20	20-27	3/4	320	1300	20	3.7	248	32	23	13	3/8	8431 1013 10
RTP2600-HR25	20-36	1	700	2600	10	5	300	34	23	13	3/8	8431 1026 10
RTP4100-HR25	30-45	1	1000	4100	10	8.7	335	41	31	13	3/8	8431 1040 10
RTP8100-GIR38	33-52	1 1/2	2200	8100	10	13.5	444	51	50	13	1/2	8431 1081 10

^aWeight excluding reaction bar.

RTP accessories

Accessories included

Model	Description	Ordering No.
RTP1300	Reaction bar, S-type	4210 4480 90
RTP2600	Reaction bar, S-type	4210 4480 94
RTP4100	Reaction bar, S-type	4210 4480 93
RTP8100	Reaction bar, S-type	4210 4480 92
RTP1300 / 2600 / 4100	Hose kit, Turbo 13 M10, BSP	8202 1182 07
RTP8100	Hose kit, Turbo 13 M15, BSP	8202 1181 81
RTP1300 / 2600 / 4100	Productivity kit FRL stand, BSP ^b	9090 3030 06
RTP8100	Productivity kit FRL stand, BSP ^b	9090 3030 04

^bHose not included



Optional accessories

Model	Description	Ordering No.
RTP1300 / 2600 / 4100	MultiFlex swivel 3/8 BSP	8202 1350 22
RTP8100	MultiFlex swivel 1/2 BSP	8202 1350 24
RTP1300 / 2600 / 4100	Trigger guard	4210 4759 90
RTP1300	Suspension yoke	4210 3088 83
RTP2600	Suspension yoke	4210 3088 82
RTP4100	Suspension yoke	4210 3088 81
RTP8100	Suspension yoke	4210 4780 90
RTP1300	Reaction bar, sliding-drive	4210 4752 90
RTP1300	Reaction bar, steel bar	4210 4757 90
RTP1300	Reaction bar, square bracket	4210 4758 90
RTP2600	Reaction bar, sliding-drive	4210 4752 93
RTP2600	Reaction bar, steel bar	4210 4757 93
RTP2600	Reaction bar, square bracket	4210 4758 93
RTP4100	Reaction bar, sliding-drive	4210 4752 91
RTP4100	Reaction bar, steel bar	4210 4757 91
RTP4100	Reaction bar, square bracket	4210 4758 91
RTP8100	Reaction bar, sliding-drive	4210 4752 92
RTP8100	Reaction bar, steel bar	4210 4757 92



NOTE: All reaction bars includes a snap ring

Service kits

Model	Description	Ordering No.
RTP1300	Small parts kit	4082 0125 90
RTP2600	Small parts kit	4082 0148 90
RTP4100	Small parts kit	4082 0116 91
RTP8100	Small parts kit	4082 0126 90
RTP1300	Service kit	4081 0510 90
RTP2600	Service kit	4081 0510 90
RTP4100	Service kit	4081 0504 90
RTP8100	Service kit	4081 0511 90



LTP and LMP

Pneumatic nutrunner



With the Pistol Nutrunner LTP and LMP from Atlas Copco you get the highest possible torque and speed in relation to the weight of the tool. Fast, accurate and highly operator friendly, the tools are reversible for maximum flexibility. The rotary dial mounted on the tool allows the operator to select different torque levels without changing the tool. The LTP is ideal for situations where several different assembly operations take place, multi-stage tightening operations are required and several different torque settings are needed.

With the Atlas Copco LMP/LTP61 range of twin-motor pistol grip nutrunners you get the highest possible torque and speed in relation to the weight of the tool. Fast, accurate and highly user-friendly, the tools are available in reversible versions for maximum flexibility.

Fast and accurate

In LTP/LMP61 tools the twin motor concept provides extremely fast rundown with good torque accuracy, even on soft joints.

Reversible for maximum flexibility

Being able to loosen fasteners without changing tools saves time and effort and raises productivity.

Operator friendly

Our pistol grip nutrunners are comfortable to operate. The reaction bar eliminates reaction forces and the exhaust through the handle arrangement keeps noise levels low.



LTP Shut-off



Model	Bolt Size mm	Square Drive In	Torque Range At 6.3 Bar		Min Torque At 3 Bar		Free Speed R/Min	Weight ^a		Length mm	Cs Distance mm	Consumption At Free Speed		Inlet Thread In	Spline Type	Ordering No.
			Nm	ft lb	Nm	ft lb		kg	lb			l/s	cfm			
LTP61 H100-13	M12	1/2	55-100	40-75	45	35	1800	3	6.6	223	29	20	42	3/8	3	8431 0800 07
LTP61 H170-13	M14	1/2	95-170	70-125	70	50	1100	3	6.6	223	29	20	42	3/8	3	8431 0800 14
LTP61 H230-19	M16	3/4	125-230	90-170	85	60	820	3	6.6	223	29	20	42	3/8	3	8431 0800 21
LTP61 H350-20	M18	3/4	190-350	140-255	145	105	520	3.9	8.6	260	31	20	42	3/8	4	8431 0800 28
LTP61 H500-20	M20	3/4	275-500	200-370	220	160	360	3.9	8.6	260	31	20	42	3/8	4	8431 0800 35
LTP61 H700-25	M22	1	360-650	265-480	280	207	280	4.5	9.9	305	34	20	42	3/8	5	8431 0800 42
LTP61 H900-25	M24	1	480-870	350-640	300	220	210	4.5	9.9	282	32	20	42	3/8	5	8431 0800 49
LTP61 H1500-25	M30	1	850-1500	625-1100	700	516	115	6.8	14.5	323	42	20	42	3/8	9	8431 0800 56
Reversible																
LTP61 HR100-13	M12	1/2	55-100	40-75	45	35	1800	3	6.6	235	30	20	42	3/8	3	8431 0801 08
LTP61 HR170-13	M14	1/2	95-170	70-125	70	50	1100	3	6.6	238	30	20	42	3/8	3	8431 0801 15
LTP61 HR230-19	M16	3/4	125-230	90-170	85	60	820	3	6.6	275	34	20	42	3/8	3	8431 0801 22
LTP61 HR350-20	M18	3/4	190-350	140-255	145	105	520	3.9	8.6	275	34	20	42	3/8	4	8431 0801 29
LTP61 HR500-20	M20	3/4	275-500	200-370	220	160	360	3.9	8.6	275	34	20	42	3/8	4	8431 0801 36
LTP61 HR700-25	M22	1	360-650	265-480	280	207	280	4.5	9.9	305	34	20	42	3/8	5	8431 0801 43
LTP61 HR900-25	M24	1	480-870	350-640	300	220	210	4.5	9.9	305	34	20	42	3/8	5	8431 0801 50
LTP61 HR1500-25	M30	1	850-1500	625-1100	700	516	115	6.8	14.5	345	42	20	42	3/8	9	8431 0801 57
LTP61 HR1900-38	M30	1 1/2	1050-1900	770-1400	800	590	90	14.1	31	380	68	20	42	3/8	8	8431 0801 64

Model	Bolt Size mm	Square Drive In	Torque Range At 6.3 Bar		Min Torque At 3 Bar		Free Speed R/Min	Weight A		Length mm	Cs Distance mm	Consumption At Free Speed		Inlet Thread In	Spline Type	Ordering No.
			Nm	ft lb	Nm	ft lb		kg	lb			l/s	cfm			
LTP61 HR100-13-MT	M12	1/2	55-100	40-75	45	35	1800	3.3	7.3	288	30	20	42	3/8	3	8431 0806 02
LTP61 HR170-13-MT	M14	1/2	95-170	70-125	70	50	1100	3.3	7.3	288	30	20	42	3/8	3	8431 0806 09
LTP61 HR230-19-MT	M16	3/4	125-230	90-170	85	60	820	3.3	7.3	288	34	20	42	3/8	3	8431 0806 16
LTP61 HR350-20-MT	M18	3/4	190-350	140-255	145	105	520	4.2	9.2	325	34	20	42	3/8	4	8431 0806 23
LTP61 HR500-20-MT	M20	3/4	275-500	200-370	220	160	360	4.2	9.2	325	34	20	42	3/8	4	8431 0806 30
LTP61 HR700-25-MT	M22	1	360-650	265-480	280	207	280	4.8	10.6	355	34	20	42	3/8	5	8431 0806 33
LTP61 HR900-25-MT	M24	1	480-870	350-640	300	220	210	4.8	10.6	355	34	20	42	3/8	5	8431 0806 37
LTP61 HR1500-25-MT	M30	1	850-1500	625-1100	700	516	115	7.1	15.6	395	42	20	42	3/8	9	8431 0806 44
LTP61 PH100-13	M12	1/2	60-110	45-80	45	33	700	3	6.6	223	34	20	42	3/8	3	8431 0807 04
LTP61 PH170-13	M14	1/2	100-180	75-135	70	52	440	3	6.6	223	34	20	42	3/8	3	8431 0807 12
LTP61 PH230-19	M16	3/4	130-240	95-180	90	66	320	3	6.6	223	34	20	42	3/8	3	8431 0807 17
LTP61 PH350-20	M18	3/4	210-370	155-275	150	110	200	3.9	8.6	260	34	20	42	3/8	4	8431 0807 24
LTP61 PH500-20	M20	3/4	300-520	220-380	200	150	140	3.9	8.6	260	34	20	42	3/8	4	8431 0807 31
LTP61 PH700-25	M22	1	400-680	295-500	280	205	100	4.5	9.9	305	34	20	42	3/8	5	8431 0807 38
LTP61 PH900-25	M24	1	500-900	370-665	350	260	80	4.5	9.9	282	34	20	42	3/8	5	8431 0807 41
LTP61 PH1500-25	M30	1	900-1600	665-1180	650	480	45	6.8	14.9	323	42	20	42	3/8	9	8431 0807 52
Reversible																
LTP61 PHR700-25	M22	1	400-680	295-500	280	205	100	4.5	9.9	305	34	20	42	3/8	5	8431 0807 55
LTP61 PHR900-25	M24	1	500-900	370-665	350	260	80	4.5	9.9	305	34	20	42	3/8	5	8431 0807 62
LTP61 PHR1500-25	M30	1	900-1600	665-1180	650	480	45	6.8	14.9	345	42	20	42	3/8	9	8431 0807 68
Reversible with Multi Torque unit																
LTP61 PHR900-25-MT	M24	1	500-900	370-665	350	260	80	4.8	10.6	305	34	20	42	3/8	5	8431 0807 81

^a Without reaction bar.
Recommended hose size: 13 mm.

NOTE: Change over torque is around 4% of maximum torque on a given air pressure.

LMP Non-shutoff



Model	Bolt Size mm	Square Drive in	Max Torque At 6.3 Bar		Min Torque At 3 Bar		Free Speed r/min	Weight ^a		Length mm	CS Distance mm	Air Consumption at Free Speed		Air inlet thread in	Spline Type	Ordering No.
			Nm	ft lb	Nm	ft lb		kg	lb			l/s	cfm			
Non-reversible																
LMP61 H100-13	M12	1/2	100	75	60	45	2200	3.0	6.6	223	29	20	42	3/8	3	8431 0803 05
LMP61 H170-13	M14	1/2	170	125	100	75	1400	3.0	6.6	223	29	20	42	3/8	3	8431 0803 12
LMP61 H230-19	M16	3/4	230	170	130	95	1000	3.0	6.6	223	29	20	42	3/8	3	8431 0803 19
LMP61 H350-20	M18	3/4	350	260	200	145	650	3.9	8.6	260	31	20	42	3/8	4	8431 0803 26
LMP61 H500-20	M20	3/4	500	370	300	220	450	3.9	8.6	260	31	20	42	3/8	4	8431 0803 33
LMP61 H700-25	M22	1	700	520	400	295	350	4.5	9.9	305	34	20	42	3/8	5	8431 0803 40
LMP61 H900-25	M24	1	900	665	500	365	260	4.5	9.9	282	34	20	42	3/8	5	8431 0803 47
Reversible																
LMP61 HR100-13	M12	1/2	100	75	60	45	2200	3.0	6.6	235	30	20	42	3/8	3	8431 0804 04
LMP61 HR170-13	M14	1/2	170	125	100	75	1400	3.0	6.6	238	30	20	42	3/8	3	8431 0804 11
LMP61 HR230-19	M16	3/4	230	170	130	95	1000	3.0	6.6	275	34	20	42	3/8	3	8431 0804 18
LMP61 HR350-20	M18	3/4	350	260	200	145	650	3.9	8.6	275	34	20	42	3/8	4	8431 0804 25
LMP61 HR500-20	M20	3/4	500	370	300	220	450	3.9	8.6	320	35	21	42	3/8	4	8431 0804 32
LMP61 HR700-25	M22	1	700	520	400	295	350	4.5	9.9	305	34	20	42	3/8	5	8431 0804 39
LMP61 HR900-25	M24	1	900	665	500	365	260	4.5	9.9	305	34	20	42	3/8	5	8431 0804 46
LMP61 HR1500-25	M30	1	1600	1180	900	660	140	6.8	14.9	345	42	20	42	3/8	9	8431 0804 53

^a Weight excluding reaction bar.
Recommended hose size 13 mm for hose length up to 5 m.

NOTE: Change over torque is around 4% of maximum torque on a given air pressure.

LMP and LTP Productivity kits

Model	Max air flow	Hose, 5 m	Coupling	Lubrication	Ordering No.
For small nutrunners with 3/8" BSP air inlet					
MIDI Optimizer F/RD EQ08-C10	16 l/s	Cablair 10 mm	ErgoQIC 08	Yes	8202 0850 07
For small nutrunners with 1/4" BSP air inlet					
MIDI Optimizer F/RD EQ08-C10	16 l/s	Cablair 10 mm	ErgoQIC 08	Yes	8202 0850 03
MIDI Optimizer F/RD EQ10-R10	16 l/s	Rubair 10 mm	ErgoQIC 10	Yes	8202 0850 16
For nutrunners with 3/8" BSP air inlet					
MIDI Optimizer F/RD EQ10-C13	23 l/s	Cablair 13 mm	ErgoQIC 10	Yes	8202 0850 02
For nutrunners with 1/4" BSP air inlet					
MIDI Optimizer F/RD EQ10-C13-1/4	23 l/s	Cablair 13 mm	ErgoQIC 10	Yes	8202 0850 11
For nutrunners with 3/8" BSP air inlet					
MIDI Optimizer F/RD EQ10-T13	35 l/s	Turbo 13 mm	ErgoQIC 10	Yes	8202 0850 17
For nutrunners with 1/2" BSP air inlet					
MIDI Optimizer F/R EQ10-T13	35 l/s	Turbo 13 mm	ErgoQIC 10	No	8202 0850 04
MIDI Optimizer F/RD EQ10-T13	35 l/s	Turbo 13 mm	ErgoQIC 10	Yes	8202 0850 13

LMP and LTP Accessories

For LMP/LTP61

Model	Ordering No.
Hose nipple	9000 0242 00
Exhaust hose	4210 2201 00
Protective cover	
Standard LTP61	4210 4672 00
LTP 61 with MT unit	4210 4672 01
Multi torque selector LTP61	4210 4636 95
Quick change retainer	
– 1/2" square models	4250 1190 00
– 3/4" square models	4210 3476 80
– 1" square models	4210 3524 80
Shut-off override for LTP61	4210 3545 80
Swivelling type MultiFlex connector 3/8" (BSP)	8202 1350 22
Swivelling type MultiFlex connector 3/8" (NPT)	8202 1350 28



Multi torque selector LTP61



Protective cover

Swivelling suspension yoke LMP/LTP61

Model	Ordering No.
Mounting dia Ø 54 mm	
PH/H 100-13	4210 3088 80
PH/H 170-13	
PH/H 230-19	
PH/H 350-20	
PH/H 500-20	
PH/H 700-25	
PH/H 900-25	
Mounting dia Ø 60 mm	
HR 100-13	4210 3088 84
HR 170-13	
HR 230-19	

Model	Ordering No.
Mounting dia Ø 63.5 mm	
H 1900-38	4210 3088 83
H 2800-38	
H 3800-38	
Mounting dia Ø 67 mm	
HR 350-20	4210 3088 82
HR 500-20	
PHR/HR 700-25	
PHR/HR 900-25	
HR 1900-38	4210 3088 85
HR 2800-38	
HR 3800-38	

Model	Ordering No.
Mounting dia Ø 83.5 mm	
PH/H 1500-25	4210 3088 81
PHR/HR 1500-25	

LMP and LTP Reaction arms

Spline Diameter mm	L/W/H	CC Distance mm	Ordering No.
Steel bar			
Spline 1	268/36/18		4210 1798 01
Spline 2	270/35/10		4220 1903 00
Spline 3	400/56/12		4210 2219 80
Spline 4	500/62/15		4210 2183 80
Spline 5	500/62/15		4210 2726 80
Spline 6	560/80/15		4220 1200 01
Spline 7	500/100/20		4210 3899 02
Spline 8	500/150/20		4210 3899 03
Spline 9	500/85/20		4210 3899 80
Ø 26 mm	270/34/8		4220 3491 00
Square steel bracket			
Spline 3	100/50/12		4210 2219 03
Spline 4	125/65/16		4210 2183 01
Spline 5	125/65/16		4210 2726 01
Spline 6	200/100/15		4220 1200 00
Spline 7	250/150/20		4220 1445 00
Spline 8	250/160/20		4220 1972 91
Spline 9	150/85/20		4210 3899 01
Ø 24 mm	100/60/8		4220 1029 00
Ø 26 mm	100/60/8		4220 1029 02
Ø 28 mm	100/60/8		4220 1029 01
Triangular steel bracket			
Spline 2	73/72/14		4220 2137 02
Spline 3	82/80/15		4220 2137 03
Spline 6	112/109/15		4220 2137 06
Spline 6	150/145/20		4220 2137 16
S-Type reaction bar			
Spline 3	110/18/12		4210 4480 03
Spline 4	120/22/15		4210 4480 04
Spline 5	130/25/15		4210 4480 05
Spline 6	125/25/15		4210 4480 06
Spline 7	170/40/20		4210 4480 07
Spline 8	200/65/20		4210 4480 08
Spline 9	160/40/20		4210 4480 09
L-Type aluminum bar			
Spline 3	266x300/29/15		4210 2219 08
Spline 4	144x150/42/15		4210 2183 08
Bracket stepped			
Spline 1	70/36/13		4210 1798 02
Spline 2	70/41/14		4210 2134 02
Straight aluminum bar			
Spline 3	L = 400		4210 2219 01

Spline Diameter mm	Square Drive Size (in)	CC Distance mm	Ordering No.
Sliding drive reaction bar			
Spline 3	1/2	70-120	4210 4481 83
Spline 3	3/4	70-120	4210 4481 63
Spline 4	3/4	76-126	4210 4481 84
Spline 4	3/4	82-218	4210 4616 84
Spline 5	1	80-125	4210 4481 85
Spline 5	1	82-218	4210 4616 85
Spline 9	1	80-130	4210 4481 89
Spline 9	1	80-280	4210 4616 89

Steel bar



Square steel bracket



Triangular steel bracket



Sliding drive reaction bar



S-Type reaction bar



L-Type aluminum bar



Straight aluminum bar



Extended sliding drive reaction bar



Extended sliding tube reaction bar



Bracket stepped



Airline Accessories

Ensure that your tools achieve their full potential

To ensure that you benefit from the full potential power from your tools, Atlas Copco has developed a full range of air line accessories for use with Atlas Copco tools and air motors. All accessories can be used for other applications and pneumatic equipment.

Air preparation units



Quick Couplings

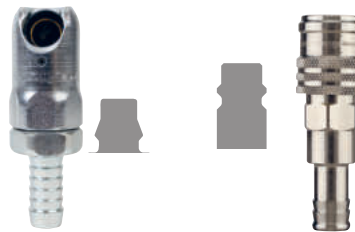

Swivel connectors



Hose reels



Balancers



Air net - quality piping solution



For more info about Airline Accessories please see Atlas Copco main catalogue or contact Atlas Copco local sales representative.

Hose Reels



HM Flex I



HM Light



HM Open XL

Model	Hose length mm	Hose type	Hose inside diameter		Connection inlet hose inside dia (cut of hose) mm	Connection distribution hose BSP	Economical air flow (at 0.2 bar pressure drop) l/s	Max air flow capacity (at 0.5 bar pressure drop) l/s	Weight kg	Ordering No.
			mm	in						
HM Light 8-8	8	PVC/PUR	8	5/16	10	1/4	4	7	3	8202 1183 30
HM Light 8-12	12	PVC/PUR	8	5/16	10	1/4	3	5	5	8202 1183 31
HM Light 10-10	10	PVC/PUR	10	3/8	10	3/8	6	10	5	8202 1183 32
HM Open 10-15	15	Rubber	10	3/8	12.5	3/8	5	9	11	8202 1183 33
HM Open 10-20	20	Rubber	10	3/8	12.5	3/8	5	7	14	8202 1183 34
HM Open 12-10	10	Rubber	12.5	1/2	12.5	1/2	13	22	12	8202 1183 35
HM Open 12-15	10	Rubber	12.5	1/2	12.5	1/2	11	17	13	8202 1183 36
HM Open XL 12-20	20	Rubber	12.5	1/2	12.5	1/2	8	14	27	8202 1183 37
HM Open XL 12-30	30	Rubber	12.5	1/2	12.5	1/2	8	12	28	8202 1183 38
HM Open XL 19-15	15	Rubber	19	3/4	19	3/4	27	44	28	8202 1183 39
HM Open XL 25-10	10	Rubber	25	1	25	1	60	95	30	8202 1183 40

Model	Hose length mm	Hose type	Hose inside dia		Connection inlet BSP male	Connection distribution hose BSP male	Air flow l/s	Weight kg	Ordering No.
			mm	in					
HM Flex L	10	Rubber	12,5	1/2	1/2	1/2	22	16	8202 1181 56

Max working pressure 15 bar on all models.

Pivoting brackets for HM OPEN and HM OPEN XL models needs to be ordered separately



HM Open

Blow guns BG-series

Model	Version	Working pressure bar	Air flow l/s	Weight		Air inlet thread BSP	Ordering No.
				kg	lb		
BG 2603-HF	Long tube, high flow	6.3	7.5	0.13	0.29	1/4	8202 1006 04
BG 2604-SHF	Short tube	6.3	4.3	0.12	0.26	1/4	8202 1006 05
BG 2605-STSS	Short tube, star tip	6.3	6.6	0.12	0.26	1/4	8202 1006 06
BG 2606-ST	Long tube, star tip, silencer	6.3	6.3	0.14	0.31	1/4	8202 1006 07

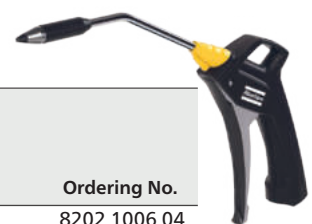

Impact Wrenches



LMS58 HR25



LMS18 HR13



LMS38 HR13

LMS pistol grip impact wrenches have a wide operating range. Equipped with an advanced impact mechanism, LMS will give you powerful tightening and disassembly with negligible reaction force.

The high capacity-to-weight ratio and state-of-the-art impact mechanism also help to minimize operator strain and vibration.

The tools have a Grease Retaining System ensuring optimum tool performance with long service intervals.

Model	Bolt size mm	Square drive size in	Torque range Nm	Max torque Nm	Free speed r/min	Weight kg	Length excl anvil mm	Air consumption l/s	Rec. hose size mm	Air inlet thread BSP	Retainer			Ordering No.
											Pin	Ring	T. hole	
LMS08 HR10	M6-8	3/8"	7-45	65	14000	0.90	185	2.5	6.3	1/4"	☑	-	-	8434 1080 00
LMS08 HR42	M6-8	1/4" ^a	7-35	60	14000	0.9	186	2.5	6.3	1/4"	-	-	-	8434 1080 05
LMS18 HR13	M10	1/2"	10-110	150	8100	1.45	144	8.5	10	1/4"	☑	-	-	8434 1180 00
LMS18 HR10	M10	3/8"	10-90	120	8100	1.45	148	6.5	10	1/4"	☑	-	-	8434 1180 01
LMS18 HR13/F	M10	1/2"	10-110	150	8100	1.45	144	8.5	10	1/4"	-	☑	-	8434 1180 02
LMS18 HR10/F	M10	3/8"	10-90	120	8100	1.45	148	6.5	10	1/4"	-	☑	-	8434 1180 03
LMS28 HR13	M12	1/2"	30-210	390	9500	1.85	146	8.5	10	3/8"	☑	-	-	8434 1280 00
LMS28 HR13/F	M12	1/2"	30-210	390	9500	1.85	146	8.5	10	3/8"	-	☑	-	8434 1280 01
LMS38 HR13	M14-16	1/2"	40-375	850	8000	2.6	167	10	10	3/8"	☑	-	-	8434 1380 00
LMS38 HR13/F	M14-16	1/2"	40-375	850	8000	2.6	167	10	10	3/8"	-	☑	-	8434 1380 01
LMS48 HR20	M16-18	3/4"	100-550	1375	6500	3.3	173	12	12.5	3/8"	-	-	☑	8434 1480 00
LMS58 HR25	M20-22	1"	300-800	1900	5500	4.8	210	14.5	12.5	3/8"	-	-	☑	8434 1580 00
LMS58 HR20	M18-20	3/4"	300-800	1900	5500	4.8	210	14.5	12.5	3/8"	-	-	☑	8434 1580 01
LMS68 HR25	M22-30	1"	600-1800	4450	5000	9.8	252	28	16	1/2"	-	-	☑	8434 1680 01

^a Female hex quick change chuck Torque measured from Skidmore with fixed sensors



LMS68 GIR25

LMS straight versions offer superior performance with a maximum torque of 10,000 reaction-free Nm.

The high capacity-to-weight ratio and advanced impact mechanism also help to minimize operator strain and vibration.

The tools have a Grease Retaining System ensuring optimum tool performance with long service intervals.



LMS08 SR10

Model	Bolt size mm	Square drive size in	Torque range Nm	Max torque Nm	Free speed r/min	Weight kg	Length excl anvil mm	Air consumption l/s	Rec. hose size mm	Air inlet	Retainer			Ordering No.
											Pin	Ring	Through hole	
LMS08 SR42	M22-30	1/4" ^a	7-35	60	12500	0.85	185	5,5	6.3	1/4"	-	-	-	8434 1081 06
LMS08 SR10	M22-30	3/8"	7-45	65	12500	0.85	184	5,5	6.3	1/4"	☒	-	-	8434 1081 11
LMS68 GIR25	M22-30	1"	600-1800	4450	5000	9.6	339	28	16	1/2"	-	-	☒	8434 1680 00
LMS68 GOR25	M22-30	1"	600-1800	4450	5000	9.6	339	28	16	1/2"	-	-	☒	8434 1680 02
LMS88 GIR38	M30-42	1 1/2"	1000-5500	10000	3800	15.0	381	33	16	1/2"	-	-	☒	8434 1880 00
LMS88 GOR38	M30-42	1 1/2"	1000-5500	10000	3800	15.0	381	33	16	1/2"	-	-	☒	8434 1880 01

^a Female hex. quick change chuck.
GOR = Outside trigger.

GIR = Inside trigger.
Torque measured from Skidmore with fixed sensors

Accessories

Suspension yoke	Ordering No.
LMS18-58	4250 0872 90
LMS68 GIR25/GOR25/HR25	4250 0677 81
LMS88 GIR38/GOR38	0371 1102 00

Service Kits

	Ordering No.
LMS08	4081 0465 90
LMS18	4081 0466 90
LMS28	4081 0467 90
LMS38	4081 0468 90
LMS48	4081 0461 90
LMS58	4081 0445 90
LMS68	4081 0442 90
LMS88	4081 0443 90

Hydraulic torque wrenches





TFX-04
15/35/115

RTX 04203.0.001A RTX04-28-203.0001A

SDF 8.8

Torcflex

Premium Square Drive Range



Scan me to view the webpage!

The new Torcflex Hydraulic Torque wrench, the torque wrench you didn't know you needed.

The new Torcflex Torque Wrench line brings innovation to the hydraulic torque market, with increased safety at the heart of everything.

New features include: The **co-axial coupling**; this will drastically reduce set-up time and increase safety, a **retained reaction arm**; this will stop the drop hazard, and ensure the reaction arm stays on the tool, an **integral square drive**; which will prevent drop hazards and accidental loss of components and a **new adjustable support handle**; this is offered as standard with every wrench.



Atlas Copco

ACTIVARMR®

ACTIVARMR®

Atlas Copco

TF Series

Square drive hydraulic torque wrench

Atlas Copco TF Series of hydraulic wrench, offers high torque output, reliability and increased efficiency.



Monobloc aluminium housing

High strength, lightweight housing: Designed to give superior rigidity and strength resulting in excellent torque to weight ratio and durability. Housing has multiple docking points for support handle.

Co-Axial Hose and Coupling

The launch of the Co-Axial coupling and hose system is an innovative solution to increase productivity and reduce fatigue of the operator. Optional traditional twin swivel version available.

Retained Reaction Arm

Prevents drop hazard and provides right first time reaction arm positioning.

Reaction Pawl

Reduces operator intervention and increases tightening speed.

Ergonomic Support Handle

Multiple attachment points and quick rotational adjustment improves operator safety.

High strength steel boot

The reaction arm integral hazard warning stripes comes as standard.

Square Drive with Integrated Retainer

Single piece, quick change square drive prevents drop hazards and accidental loss of separate retainer.

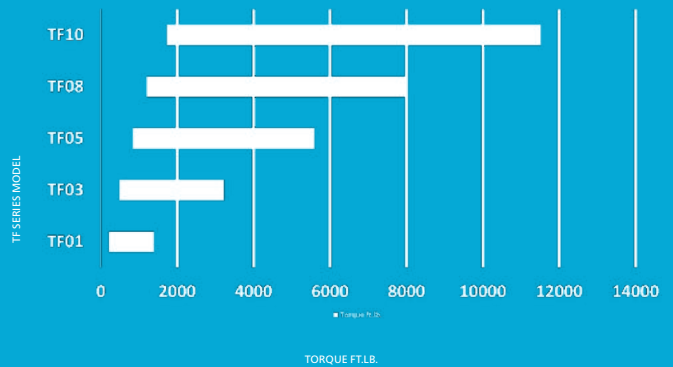

Square Drive Sizes

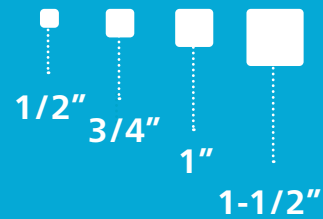

TF Series technical information



Model	Square Drive in	Torque				Weight		Ordering No Co-axial/Twin
		ft. lb.		Nm		lb	kg	
		min	max	min	max			
TF01	3/4	209	1390	283	1885	6.06 / 6.44	2.75 / 2.92	8434 2406 05 / 8434 2410 15
TF03	1	485	3230	657	4379	12.06 / 12.43	5.47 / 5.64	8434 2409 95 / 8434 2409 94
TF05	1-1/2	839	5590	1137	7579	20.3 / 20.68	9.21 / 9.38	8434 2411 16 / 8434 2411 17
TF08	1-1/2	1200	8000	1627	10847	27.23 / 27.26	12.35 / 12.52	8434 2411 49 / 8434 2411 50
TF10	1-1/2	1728	11520	2343	15619	34.99 / 35.36	15.87 / 16.04	8434 2415 24 / 8434 2415 25

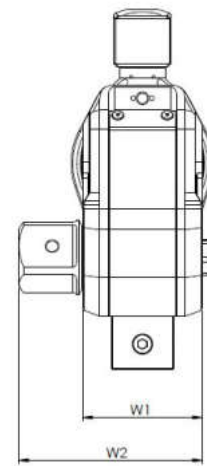
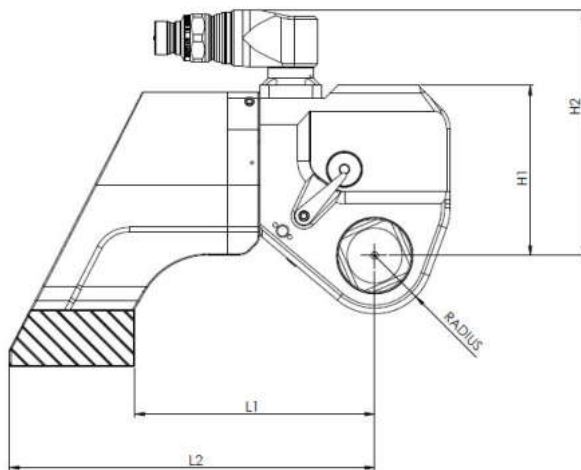

Model	Dimensions													
	L1		L2		H1		H2*		Radius		W1		W2	
	in	mm	in	mm	in	mm	in	mm	in	mm	in	mm	in	mm
TF01	3.98	101	6.18	157	3.03	77	4.97 / 4.79	126 / 122	0.97	24.7	1.97	50	2.87	73
TF03	4.96	126	8.03	204	3.82	97	5.82 / 5.64	148 / 143	1.29	32.8	2.64	67	3.7	94
TF05	6.34	161	9.69	246	4.51	114.5	6.51 / 6.32	165 / 161	1.54	39.1	3.15	80	4.84	123
TF08	6.73	171	10.91	277	4.96	126.1	6.97 / 6.78	177 / 172	1.76	44.6	3.58	91	5.12	130
TF10	8.19	208	12.32	313	5.87	149	7.87 / 7.68	200 / 195	3.76	95.6	3.94	100	5.51	140

Designs and specifications are subject to change without notice or obligation. Read all safety instructions in the manual before usage.

*Values separated by slash are for model variants: Co-axial / Twin

TF Series standard setup

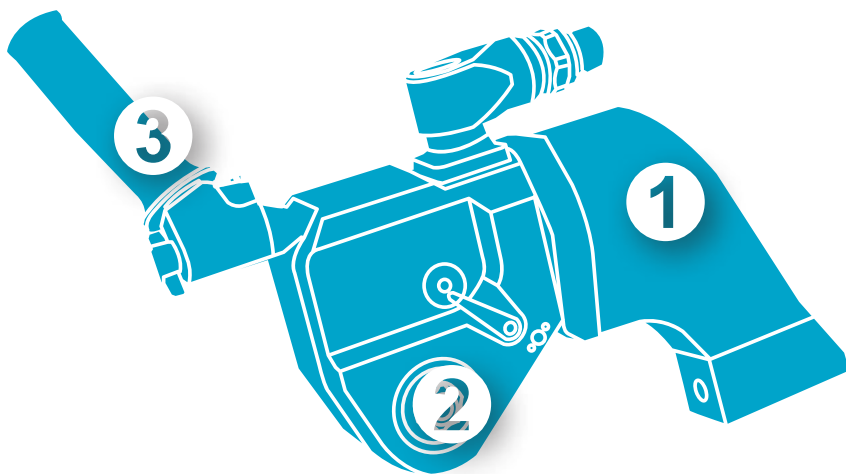

All TF wrenches are provided with the following equipment as standard:

1. Adjustable Retained Reaction Arm.
2. Square Drive with Integrated Retainer for use with impact sockets.
3. Fully Adjustable Ergonomic Support Handle.
4. Peli-case style packaging and custom foam.
5. All TF wrenches can be supplied with Co-Axial coupling or standard twinline.

Use high quality impact sockets

Hydraulic wrenches in TF Series offer extremely high torque output. Excellent power to weight ratio and range of 5 models covering torque from 283 – 15619 Nm (209 - 11520 Ft. lb.).

TF & RT Series accessories



These are available in various sizes. Please contact our sales team for more information.

Ordering No	Size	Description
8434 2101 72	1/2"	RT0.5-HX-008
8434 2138 44	10mm	RT0.5-HX-10MM
8434 2138 47	12mm	RT0.5-HX-12MM
8434 2138 50	14mm	RT0.5-HX-14MM
8434 2138 53	16mm	RT0.5-HX-16MM
8434 2138 56	17mm	RT0.5-HX-17MM
8434 2138 59	18mm	RT0.5-HX-18MM
8434 2138 62	19mm	RT0.5-HX-19MM
8434 2138 65	20mm	RT0.5-HX-20MM
8434 2138 68	22mm	RT0.5-HX-22MM
8434 2101 71	24mm	RT0.5-HX-24MM
8434 2138 71	5/8"	RT01-HX-010
8434 2138 74	3/4"	RT01-HX-012
8434 2138 77	7/8"	RT01-HX-014
8434 2056 94	1"	RT01-HX-100
8434 2138 83	10mm	RT01-HX-10MM
8434 2138 86	14mm	RT01-HX-14MM
8434 2138 89	16mm	RT01-HX-16MM
8434 2056 96	17mm	RT01-HX-17MM
8434 2138 92	18mm	RT01-HX-18MM
8434 2056 98	19mm	RT01-HX-19MM
8434 2057 00	20mm	RT01-HX-20MM
8434 2057 02	22mm	RT01-HX-22MM
8434 2057 04	24mm	RT01-HX-24MM
8434 2138 98	25mm	RT01-HX-25MM
8434 2138 95	26mm	RT01-HX-26MM
8434 2057 06	27mm	RT01-HX-27MM
8434 2057 14	5/8"	RT03-HX-010
8434 2057 16	3/4"	RT03-HX-012
8434 2057 18	7/8"	RT03-HX-014
8434 2057 20	1"	RT03-HX-100
8434 2139 28	1 1/8"	RT03-HX-102
8434 2139 31	1 1/4"	RT03-HX-104
8434 2139 34	1 1/2"	RT03-HX-108
8434 2139 35	15mm	RT03-HX-15MM
8434 2139 36	16mm	RT03-HX-16MM
8434 2139 37	17mm	RT03-HX-17MM
8434 2057 22	19mm	RT03-HX-19MM
8434 2057 24	22mm	RT03-HX-22MM
8434 2057 26	24mm	RT03-HX-24MM
8434 2139 43	26mm	RT03-HX-26MM
8434 2057 28	27mm	RT03-HX-27MM
8434 2139 46	30mm	RT03-HX-30MM
8434 2057 30	32mm	RT03-HX-32MM
8434 2139 49	36mm	RT03-HX-36MM

Ordering No	Size	Description
8434 2139 55	38mm	RT03-HX-38MM
8434 2139 58	41mm	RT03-HX-41MM
8434 2139 61	46mm	RT03-HX-46MM
8434 2139 64	55mm	RT03-HX-55MM
8434 2140 04	1"	RT-05
8434 2140 13	1 1/4"	RT05-HX-104
8434 2139 97	19mm	RT05-HX-19MM
8434 2140 00	22mm	RT05-HX-22MM
8434 2140 03	24mm	RT05-HX-24MM
8434 2140 06	26mm	RT05-HX-26MM
8434 2057 36	27mm	RT05-HX-27MM
8434 2140 10	30mm	RT05-HX-30MM
8434 2140 12	32mm	RT05-HX-32MM
8434 2057 38	36mm	RT05-HX-36MM
8434 2057 39	38mm	RT05-HX-38
8434 2057 40	41mm	RT05-HX-41MM
8434 2057 42	46mm	RT05-HX-46MM
8434 2140 20	50mm	RT05-HX-50MM
8434 2140 21	55mm	RT05-HX-55MM
8434 2140 45	24mm	RT08-HX-24MM
8434 2140 48	27mm	RT08-HX-27MM
8434 2140 69	1"	RT10-HX-100
8434 2140 72	1 1/2"	RT10-HX-108
8434 2140 75	32mm	RT10-HX-32MM
8434 2057 46	36mm	RT10-HX-36MM
8434 2057 48	41mm	RT10-HX-41MM
8434 2057 50	46mm	RT10-HX-46MM
8434 2057 52	50mm	RT10-HX-50MM
8434 2140 81	55mm	RT10-HX-55MM

Hex drive dimensions

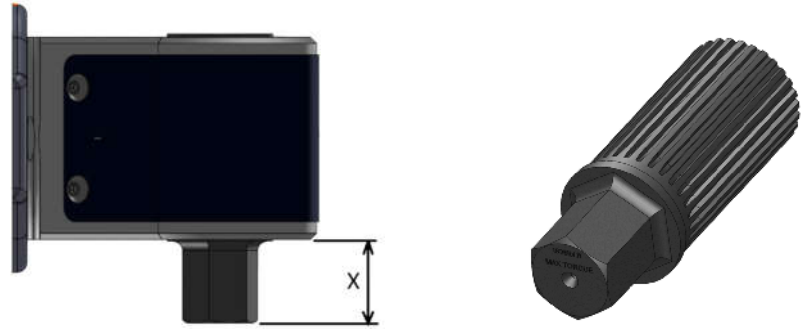

RT Hex Drives - Inch Series

Wrench Ref	Hex AF inch	X inch	Max Torque lbf.ft
RT-0.5	3/8	0.472	149
RT-0.5	7/16	0.512	236
RT-0.5	1/2	0.551	353
RT-0.5	5/8	0.591	689
RT-01	5/8	0.709	689
RT-01	3/4	0.827	1191
RT-01	7/8	0.945	1892
RT-01	1	1.063	2824
RT-03	3/4	0.906	1191
RT-03	7/8	1.024	1892
RT-03	1	1.142	2824
RT-03	1 1/4	1.299	5516
RT-05	1	1.142	2824
RT-05	1 1/4	1.299	5516
RT-05	1 1/2	1.417	9531
RT-05	1 3/4	1.614	15135
RT-08	1	1.142	2824
RT-08	1 1/4	1.299	5516
RT-08	1 1/2	1.417	9531
RT-08	1 3/4	1.614	15135
RT-10	1 1/4	1.339	5516
RT-10	1 1/2	1.457	9531
RT-10	1 3/4	1.654	15135
RT-10	2	1.850	22593

RT Hex Drives - Metric Series

Wrench Ref	Hex AF mm	X mm	Max Torque Nm
RT-0.5	10	12	234
RT-0.5	12	13	404
RT-0.5	14	14.5	641
RT-0.5	17	16	1147
RT-01	17	19	1147
RT-01	19	21	1602
RT-01	22	24.5	2486
RT-01	27	28	4596
RT-03	19	23	1602
RT-03	22	26.5	2486
RT-03	27	30	4596
RT-03	32	35	7652
RT-05	27	30	4596
RT-05	32	35	7652
RT-05	36	39	10895
RT-05	41	45	16094
RT-08	27	30	4596
RT-08	32	35	7652
RT-08	36	39	10895
RT-08	41	45	16094
RT-10	32	36	7652
RT-10	36	40	10895
RT-10	41	46	16094
RT-10	46	50	22730
RT-10	50	52	29190

Hex drives with retainer assembly

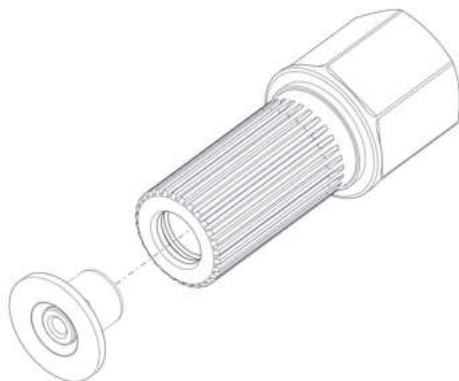

RT / TF Series	Retainer SAP No
RT01	4222212703
RT03	4222210294
RT05	4222210399
RT08	4222210504
RT10	4222210579

Retainer button to be purchased, if using with the TF too

RT Series

Square drive
hydraulic torque wrench

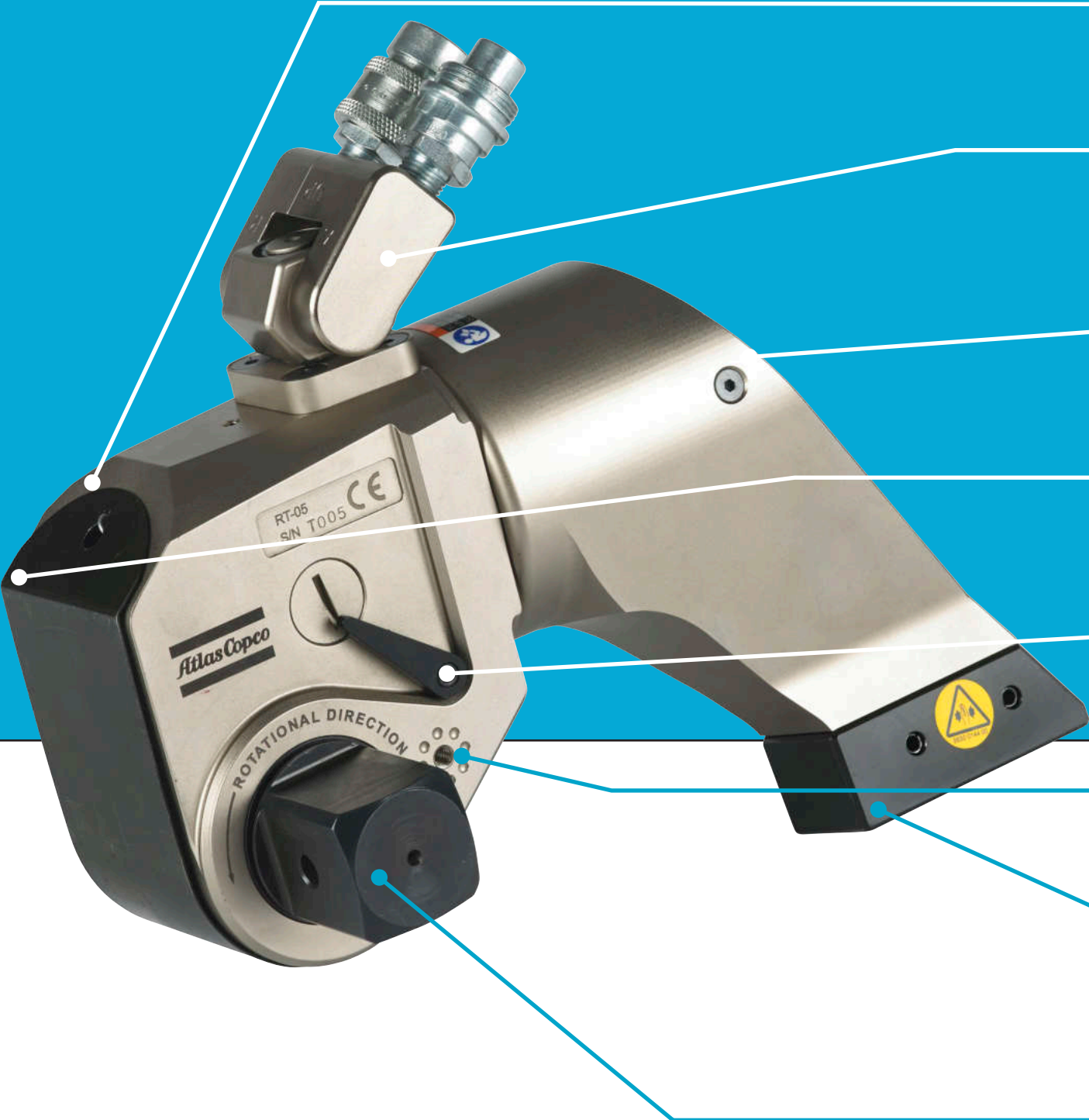

Atlas Copco RT Series standard hydraulic wrenches offer extremely high torquing power. There are nine models to choose from.

Monobloc aluminium housing

A single block of aircraft quality aluminum alloy is used to produce the RT Series housing. This allows the tool to produce massive amounts of torque, while having an amazing power-to-weight ratio.

Multi-axis swivel

Greater range of movement on multiple axis allows the hose to move easier compared to single axis swivels.

Splined reaction arm

Splined reaction arm makes the tool more compact and allows the reaction arm to be adjusted for maximum safety.

Spring-loaded shroud

Spring loaded shroud absorbs energy during operation.

Safety pawl

Increases speed and reduces operator intervention.

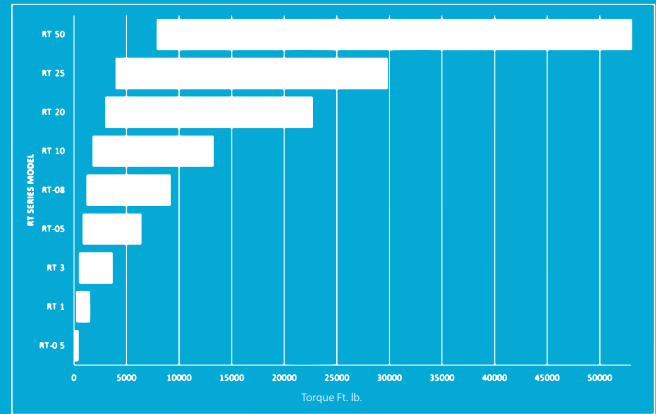

Square Drive Sizes

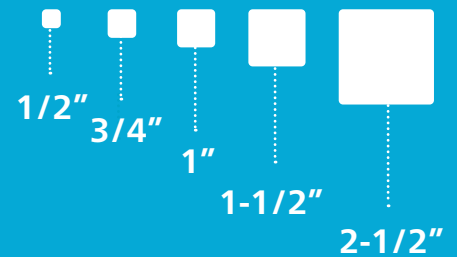

Tapped handle security point

High strength steel boot

The reaction arm boot comes standard. Copper boot also available.

Splined square drive

The RT Series splined square drive distributes load evenly through the drive components, providing full heavy-duty transmission of force. Direct Hex Drives and Hex Adapters are available.



RT Series technical information



Model	Square Drive in	Torque				Weight		Ordering No.
		ft. lb.		Nm		lb	kg	
		min	max	min	max			
RT-0.5	1/2	60	397	81	538	0.8	0.4	8434 2010 00
RT-01	3/4	209	1390	283	1885	3.8	1.9	8434 2010 02
RT-03	1	485	3230	657	4379	7.8	3.9	8434 2010 05
RT-05	1-1/2	839	5590	1137	7579	15	7.5	8434 2010 09
RT-08	1-1/2	1200	8000	1627	10846	23	11.5	8434 2010 13
RT-10	1-1/2	1728	11520	2343	15619	26.8	13.4	8434 2010 16
RT-20	2-1/2	2964	19760	4019	26791	36	18	8434 2010 20
RT-25	2-1/2	3884	25890	5266	35102	62	31	8434 2010 25
RT-50	2-1/2	7875	52500	10677	71180	96	48	8434 2010 29

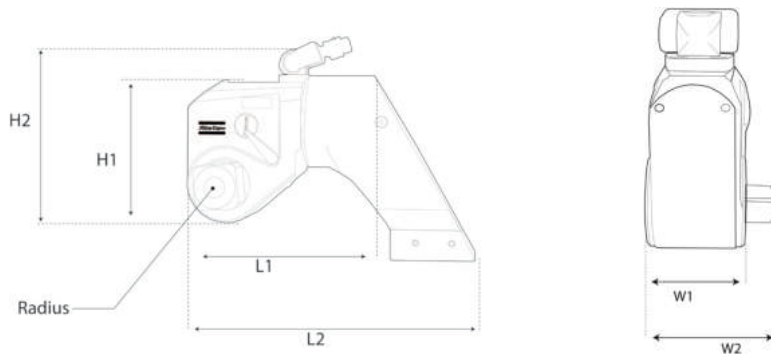

Model	Dimensions													
	L1		L2		H1		H2		Radius		W1		W2	
	in	mm	in	mm	in	mm	in	mm	in	mm	in	mm	in	mm
RT-0.5	3.15	81	4.87	125	2.35	60.5	3.62	93	0.52	13.5	1.3	33.5	1.97	50.5
RT-01	4.68	120	7.13	183	3.52	90.5	4.75	122	0.9	23	1.95	50	2.76	71
RT-03	6.04	155	9.24	237	4.68	120	6.08	156	1.28	33	2.59	66.5	3.72	95.5
RT-05	7.21	185	11.23	288	5.63	144.5	7.05	181	1.44	37	3.12	80	4.9	126
RT-08	7.85	202	12.49	321	6.42	164.6	8.4	213.36	1.62	41	3.48	88	4.95	126
RT-10	9	232	13.9	357	7.2	186	9.3	239	1.87	48	3.9	100	5.5	142.5
RT-20	10.2	259	16.55	420	8.5	216	9.9	251	2.17	55.1	4.7	119	6.7	170
RT-25	12	310	18.4	473	9.1	234	11	282	2.37	61	5.2	134	7.4	191
RT-50	15.2	390	23.9	615	11.4	294	13.4	344	30.8	79	6.5	167	8.9	228

RT Series standard setup

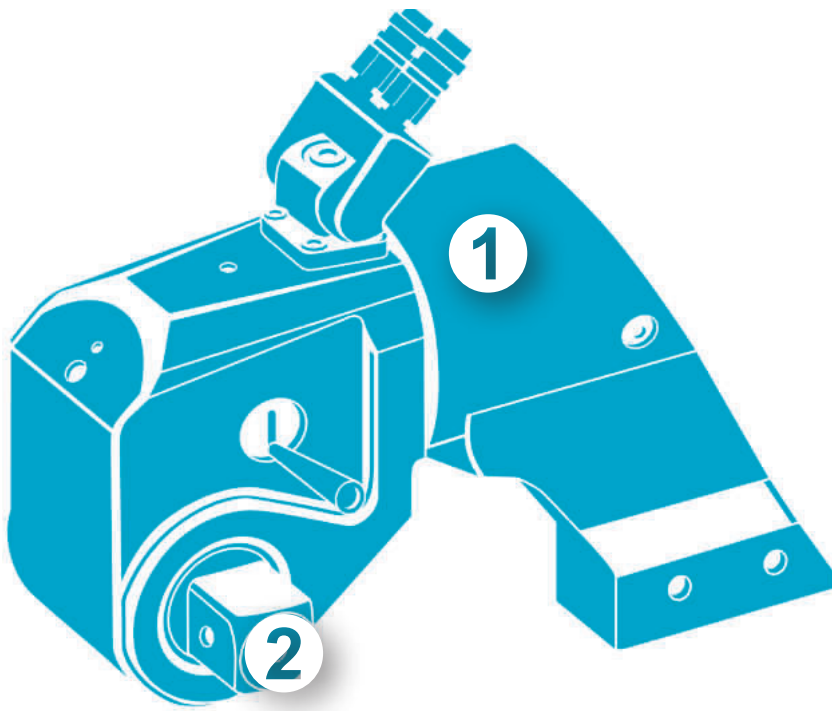

1 The RT comes with the standard reaction arm, great for many common applications.

2 The RT Series comes standard with a square drive, use with a socket.

Use high quality impact sockets

Hydraulic wrenches in RT Series offer extremely high torquing power. Excellent power to weight ratio and range of 9 models covering torque from 81 – 71180 Nm (60 - 52500 Ft. lb.) makes it the most preferred wrench in the market.

Square drive hydraulic torque wrench accessories

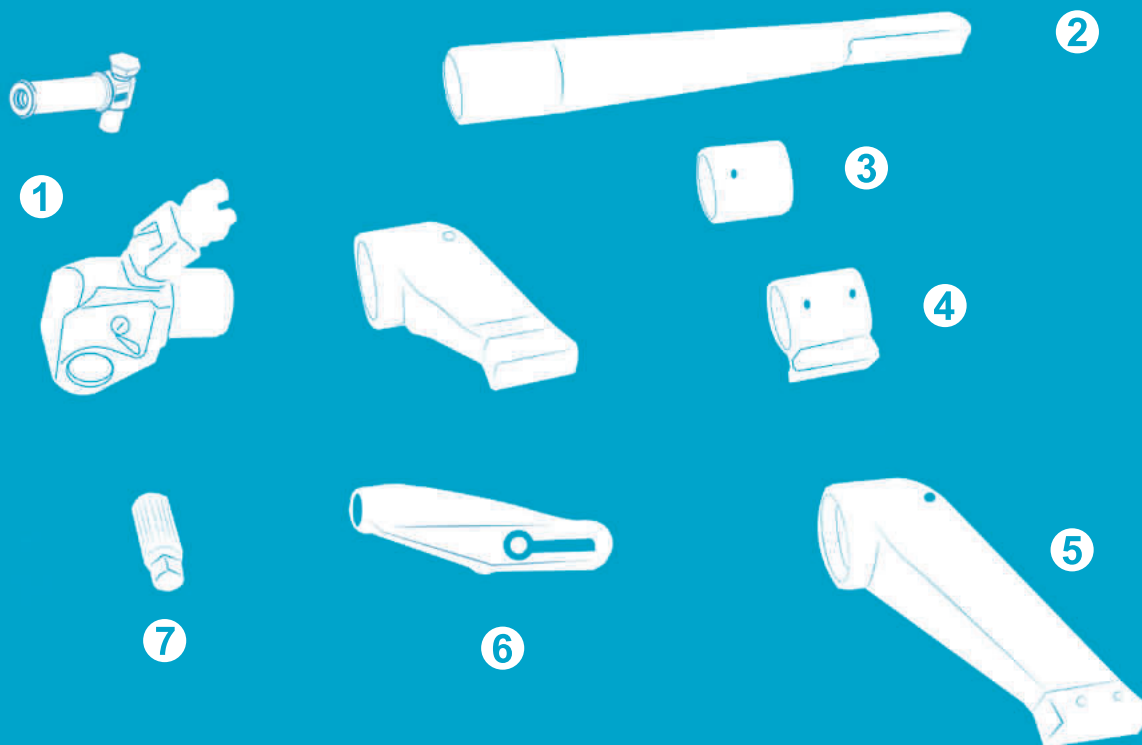

1 RT safety handle

2 Alco reaction arm

3 Steel sleeve

4 Steel sleeve with foot

5 Extended reaction arm

6 Sliding reaction arm

7 Direct hex drive

1 Support safety handle



Description	Ordering No.
Handle for RT3, RT5, RT8, RT10	8434 2170 31

2 Alco arm



Description	Ordering No.
RT0.5-ALC	4222 2126 76
RT01-ALC	4222 2102 64
RT03-ALC	8434 2057 10
RT05-ALC	8434 2139 88
RT08-ALC	8434 2140 36
RT10-ALC	8434 2140 60

3 Steel sleeve



Description	Ordering No.
RT0.5-SSLV	4222 2126 88
RT01-SSLV	8434 2057 08
RT03-SSLV	8434 2057 32
RT05-SSLV	8434 2140 30
RT08-SSLV	8434 2140 51
RT10-SSLV	8434 2140 90

4 Steel sleeve with foot



Description	Ordering No.
RT01-SSLVF	8434 2057 09
RT03-SSLVF	8434 2139 79
RT05-SSLVF	8434 2139 80

5 Ext arm



Description	Ordering No.
RT0.5-EXT	4222 2126 82
RT01-EXT	8434 2056 92
RT03-EXT	8434 2057 12
RT05-EXT	8434 2057 34
RT08-EXT	8434 2140 42
RT10-EXT	8434 2140 66

6 Sliding reaction arm



Description	Ordering No.
RT-01 Sliding Ext	8434 2057 33
RT-01 Sliding Std	8434 2150 95
RT-03 Sliding Ext	8434 2150 37
RT-03 Sliding Std	8434 2150 30
RT-05 Sliding Ext	8434 2150 36
RT-05 Sliding Std	8434 2150 35
RT-08 Sliding Ext	8434 2150 32
RT-08 Sliding Std	8434 2150 31
RT-10 Sliding Ext	8434 2150 34
RT-10 Sliding Std	8434 2150 33

STD= Standard

EXT=Extended

Torcflex

Direct-Fit Range



Scan me to view the webpage!

The Torcflex Hydraulic Torque Wrench, best in class when it comes to safety and reliability.

The Torcflex low-profile hydraulic torque wrench is quick and easy to set-up and is perfect for those low clearance applications which are difficult to access.

The Torcflex wrench can be equipped with the co-axial or twin-line set-ups as standard. There are additional safety benefits and increased user efficiencies, with the retained link pin and support handle offered as standard.



TFX Series

Low profile hydraulic torque wrench

Atlas Copco TFX Series Low Profile Hydraulic Torque Wrenches eliminate problems with tight clearances, whilst increasing user efficiency.

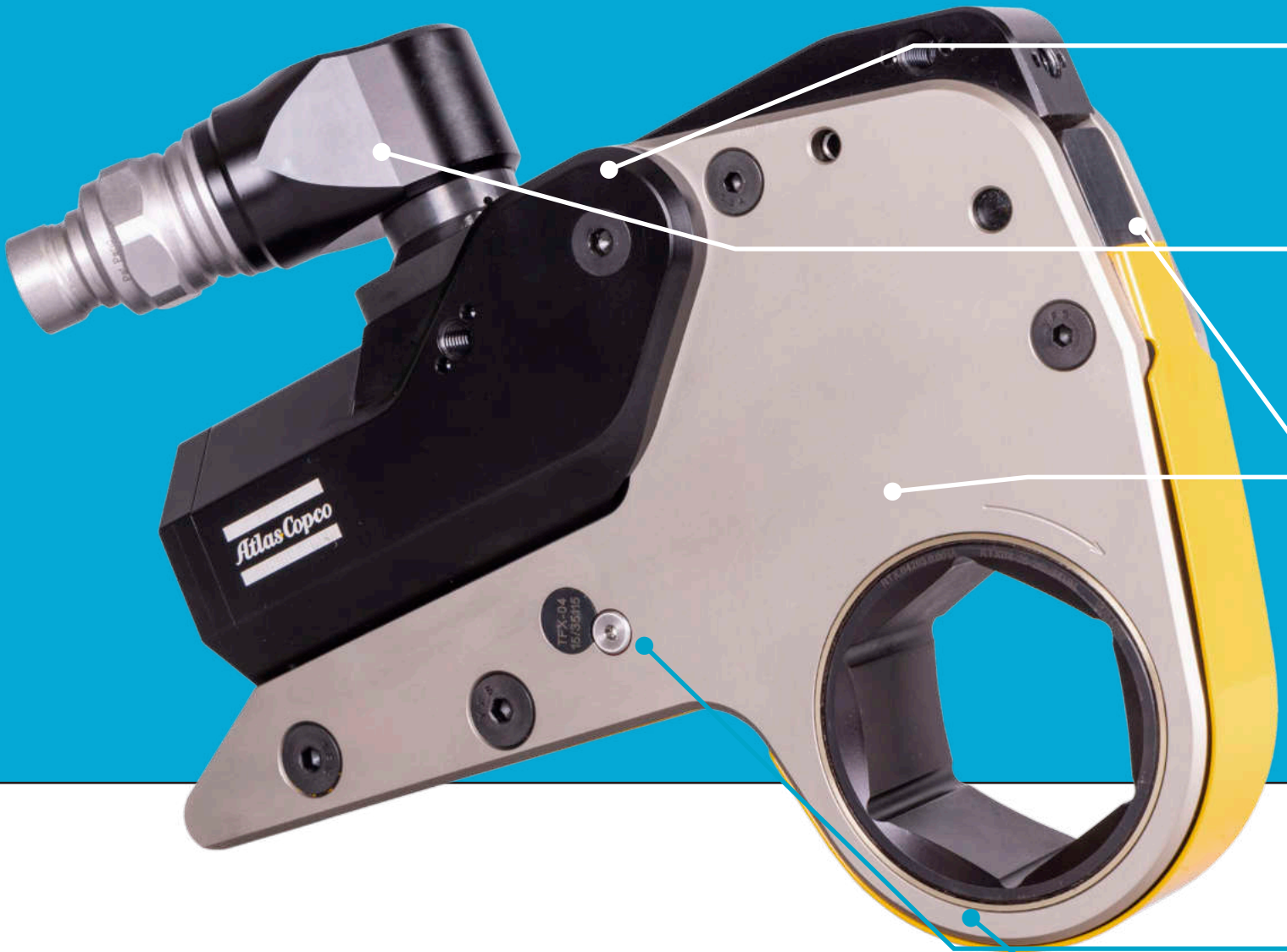

Powerhead

Made from aircraft grade alloy for optimum strength to weight ratio. Can be used with legacy ratchet links.

Co-Axial Hose and Coupling

The launch of the Co-Axial coupling and hose system is an innovative solution to increase productivity and reduce fatigue of operator
Optional Traditional Twin Swivel version available.

Interchangeable Ratchet Link

Made from premium alloy steel for maximum durability. Interchangeable with RTX powerheads.

Reaction pawl

Reduces operator intervention and increases tightening speed.

Retained Link Pin

Patented design eliminates drop hazard and prevents accidental pin disengagement.

Thin Nose Radius

The use of premium grade steel allows the ratchet links to be optimised to allow fit onto low clearance applications.

Support Handle

Each powerhead is supplied with an ergonomic support handle.

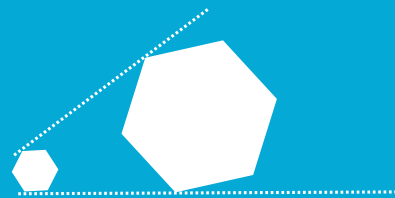
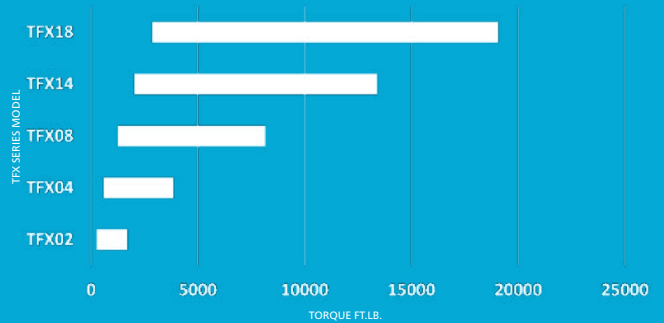

Ranges from 3/4"– 5 3/8"
15mm to 135mm AF

TFX Series technical information

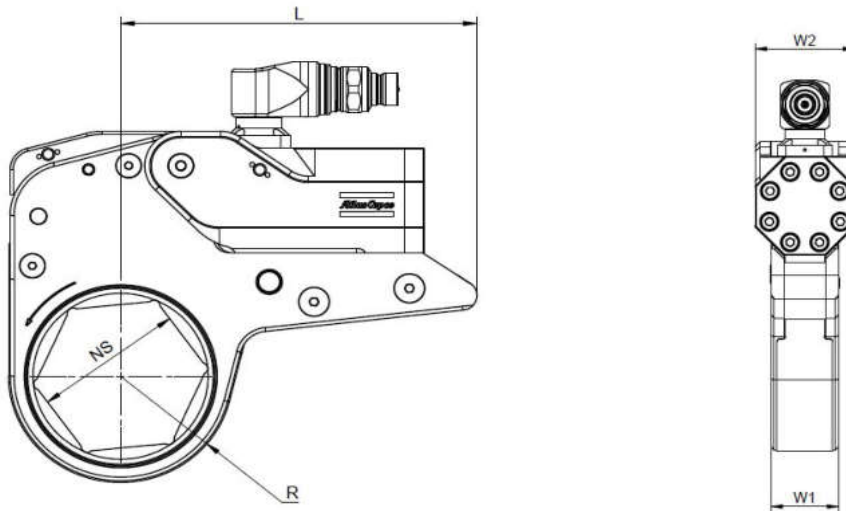

Model	Dimensions					
	L		W1		W2	
	in	mm	in	mm	in	mm
TFX02	5.49	140	1.26	32	1.81	46
TFX04	7.5	191	1.68	43	2.40	61
TFX08	9.24	235	2.08	53	3.07	78
TFX14	11.23	285	2.48	63	3.62	92
TFX18	12.69	322	2.75	70	4.13	105

* TFX30 detail coming in Q3

Model	Ratchet Link Hex Size*		Torque Range		Weight (Powerhead Only)		Ordering No. Co-Axial/Twin
	in	mm	ft.lb.	Nm	lb	kg	
	TFX02	3/4"- 2-9/16"	15-65	257-1710	348-2318	2.47 / 2.89	
TFX04	3/4" - 3-3/16"	15-80	579-3855	784-5227	4.32 / 4.72	1.96 / 2.14	8434 2411 47 / 8434 2419 76
TFX08	1 1/8" - 3-7/8"	30-100	1223-8151	1658-11051	7.25 / 7.63	3.29 / 3.46	8434 2417 87 / 8434 2420 70
TFX14	1 1/4" - 4-5/8"	32-120	2010-13400	2725-18168	11.24 / 11.62	5.1 / 5.27	8434 2424 02 / 8434 2424 05
TFX18	2 3/16" - 5 3/8"	55-135	2861-19074	3879-25861	15.26 / 15.61	6.92 / 7.08	8434 2427 13 / 8434 2427 32

Designs and specifications are subject to change without notice or obligation. Read all safety instructions in the manual before usage.

Choosing your TFX series hydraulic torque wrench

1

TFX Powerhead

All TFX Powerheads are provided with the following equipment as standard:

1. Fully Adjustable Ergonomic Support Handle.
2. Retaining pin for legacy ratchet links.
3. Peli-style packaging and custom foam.
4. Do you want a Co-Axial connection or Twin-Line? All Powerheads can be supplied with both set-ups.

2

TL Direct Fit Ratchet Links

Choose the across flat hex link size needed for your application. Also supplied with a Peli-style packaging and custom foam.

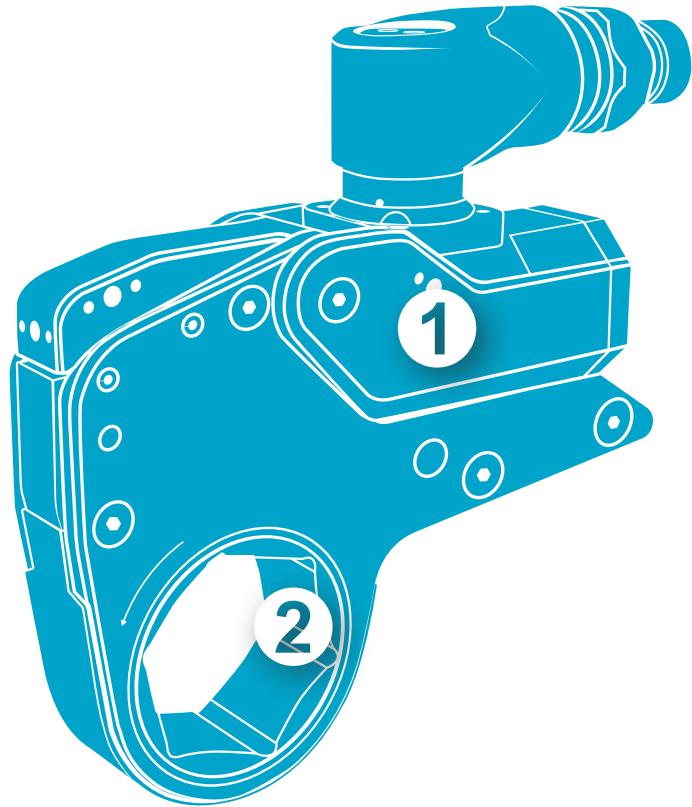

Wide range of ratchet links designed to suit low clearance applications with a range of 5 power heads, torque outputs from 348 – 25861 Nm (257 – 19074 ft. lb).

Contact your local sales office for any special design or tool fit requirements.

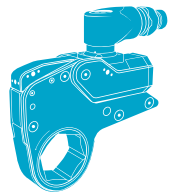

TFX02 Ratchet link sizes

Nominal Hexagon A/F Inch	Metric	Link Ref.	Nose Radius 'R' [in] (Decimal)	Nose Radius 'R' [mm] (Decimal)	Model	Ordering No.
	15	#1	1.037	26.34	TL02-15MM	8434242653
	17	#1	1.037	26.34	TL02-17MM	8434242505
3/4"	19	#1	1.037	26.34	TL02-012/19MM	8434242506
13/16"		#1	1.037	26.34	TL02-013	8434242507
7/8"	22	#1	1.037	26.34	TL02-014/22MM	8434242508
15/16"	24	#1	1.037	26.34	TL02-24MM	8434242509
1"		#1	1.037	26.34	TL02-100	8434242510
1-1/16"	27	#1	1.037	26.34	TL02-101/27MM	8434241763
1-1/8"		#1	1.037	26.34	TL02-102	8434242511
1-3/16"	30	#2	1.118	28.40	TL02-103/30MM	8434242512
1-1/4"	32	#2	1.118	28.40	TL02-104/32MM	8434241764
1-5/16"		#3	1.219	30.96	TL02-105	8434242513
	34	#3	1.219	30.96	TL02-34MM	8434242514
1-7/16"	36	#3	1.219	30.96	TL02-107/36MM	8434241765
1-1/2"		#4	1.329	33.76	TL02-108	8434242515
1-9/16"		#4	1.329	33.76	TL02-109	8434242516
1-5/8"	41	#4	1.329	33.76	TL02-110/41MM	8434241766
1-11/16"		#5	1.436	36.47	TL02-111	8434242517
1-3/4"		#5	1.436	36.47	TL02-112	8434242518
1-13/16"	46	#5	1.436	36.47	TL02-113/46MM	8434241767
1-7/8"		#6	1.548	39.32	TL02-114	8434242519
1-15/16"		#6	1.548	39.32	TL02-115	8434242520
	50	#6	1.548	39.32	TL02-50MM	8434241801
2"		#6	1.548	39.32	TL02-200	8434241768
2-1/16"		#7	1.657	42.09	TL02-201	8434242522
2-1/8"		#7	1.657	42.09	TL02-202	8434242523
2-3/16"	55	#7	1.657	42.09	TL02-203/55MM	8434241769
2-1/4"		#8	1.767	44.88	TL02-204	8434242524
	58	#8	1.767	44.88	TL02-58MM	8434242525
2-5/16"		#8	1.767	44.88	TL02-205	8434242526
2-3/8"	60	#8	1.767	44.88	TL02-206/60MM	8434241770
2-7/16"		#9	1.877	47.68	TL02-207	8434242527
2-1/2"		#9	1.877	47.68	TL02-208	8434242528
2-9/16"	65	#9	1.877	47.68	TL02-209/65MM	8434242451

Additional ratchet link sizes available upon request.

TFX04 Ratchet link sizes

Nominal Hexagon A/F Inch	Metric	Link Ref.	Nose Radius 'R' [in] (Decimal)	Nose Radius 'R' [mm] (Decimal)	Model	PTD Ordering No.
	15	#1	1.335	33.91	TL04-15MM	8434242529
	17	#1	1.335	33.91	TL04-17MM	8434242530
3/4"	19	#1	1.335	33.91	TL04-012/19MM	8434242531
13/16"		#1	1.335	33.91	TL04-013	8434242532
7/8"	22	#1	1.335	33.91	TL04-014/22MM	8434242533
15/16"	24	#1	1.335	33.91	TL04-24MM	8434242534
1"		#1	1.335	33.91	TL04-100	8434242535
1-1/16"	27	#1	1.335	33.91	TL04-101/27MM	8434242536
1-1/8"		#1	1.335	33.909	TL02-102	8434242537
1-3/16"	30	#1	1.335	33.91	TL04-103/30MM	8434242538
1-1/4"	32	#1	1.335	33.91	TL04-104/32MM	8434242539
1-5/16"		#1	1.335	33.91	TL04-105	8434242540
1-7/16"	36	#1	1.335	33.91	TL04-107/36MM	8434241771
1-1/2"		#2	1.444	36.68	TL04-108	8434242541
1-9/16"		#2	1.444	36.68	TL04-109	8434242542
1-5/8"	41	#2	1.444	36.68	TL04-110/41MM	8434241772
1-11/16"		#3	1.552	39.42	TL04-111	8434242543
1-3/4"		#3	1.552	39.42	TL04-112	8434242544
1-13/16"	46	#3	1.552	39.42	TL04-113/46MM	8434241773
1-7/8"		#4	1.662	42.21	TL04-114	8434242545
1-15/16"		#4	1.662	42.21	TL04-115	8434242546
	50	#4	1.662	42.21	TL04-50MM	8434242072
2"		#4	1.662	42.21	TL04-200	8434241774
2-1/16"		#5	1.772	45.01	TL04-201	8434242547
2-1/8"		#5	1.772	45.01	TL04-202	8434242548
2-3/16"	55	#5	1.772	45.01	TL04-203/55MM	8434241775
2-1/4"		#6	1.882	47.80	TL04-204	8434242549
	58	#6	1.882	47.80	TL04-58MM	8434242550
2-5/16"		#6	1.882	47.80	TL04-205	8434242551
2-3/8"	60	#6	1.882	47.80	TL04-206/60MM	8434241776
2-7/16"		#7	1.991	50.57	TL04-207	8434242552
2-1/2"		#7	1.991	50.57	TL04-208	8434242553
2-9/16"	65	#7	1.991	50.57	TL04-209/65MM	8434241777
2-5/8"		#8	2.101	53.37	TL04-210	8434242554
2-3/4"	70	#8	2.101	53.37	TL04-212/70MM	8434241778
2-13/16"		#9	2.218	56.34	TL04-213	8434242555
2-15/16"	75	#9	2.218	56.34	TL04-215/75MM	8434241779
3"		#10	2.331	59.21	TL04-300	8434242556
	77	#10	2.331	59.21	TL04-77MM	8434242557
3-1/16"	78	#10	2.331	59.21	TL04-301	8434242558
3-1/8"	80	#10	2.331	59.21	TL04-302/80MM	8434241780
		#10	2.331	59.21	TL04-303	8434242559

Additional ratchet link sizes available upon request.

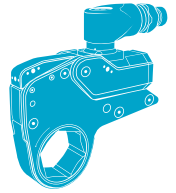

TFX08 Ratchet link sizes

Nominal Inch	Hexagon A/F Metric	Link Ref.	Nose Radius 'R' [in] (Decimal)	Nose Radius 'R' [mm] (Decimal)	Model	Ordering No.
1-1/8"		#1	1.777	45.14	TL08-102	8434242560
1-3/16"	30	#1	1.777	45.14	TL08-103/30MM	8434242561
1-1/4"	32	#1	1.777	45.14	TL08-104/32MM	8434242562
1-5/16"		#1	1.777	45.14	TL08-105	8434242563
1-7/16"	36	#1	1.777	45.14	TL08-107/36MM	8434242564
1-1/2"		#1	1.777	45.14	TL08-108	8434242565
1-9/16"		#1	1.777	45.14	TL08-109	8434242566
1-5/8"	41	#1	1.777	45.14	TL08-110/41MM	8434242567
1-11/16"		#1	1.777	45.14	TL08-111	8434242568
1-3/4"		#1	1.777	45.14	TL08-112	8434242569
1-13/16"	46	#1	1.777	45.14	TL08-113/46MM	8434242570
1-7/8"		#1	1.777	45.14	TL08-114	8434242571
1-15/16"		#1	1.777	45.14	TL08-115	8434242572
	50	#1	1.777	45.14	TL08-50MM	8434241805
2"		#1	1.777	45.14	TL08-200	8434242406
2-1/16"		#2	1.886	47.90	TL08-201	8434242573
2-1/8"		#2	1.886	47.90	TL08-202	8434242574
2-3/16"	55	#2	1.886	47.90	TL08-203/55MM	8434241806
2-1/4"		#3	1.995	50.67	TL08-204	8434242575
2-5/16"		#3	1.995	50.67	TL08-205	8434242576
2-3/8"	60	#3	1.995	50.67	TL08-206/60MM	8434241807
2-7/16"		#4	2.105	53.47	TL08-207	8434242577
2-1/2"		#4	2.105	53.47	TL08-208	8434242578
2-9/16"	65	#4	2.105	53.47	TL08-209/65MM	8434241808
2-5/8"		#5	2.215	56.26	TL08-210	8434242579
2-3/4"	70	#5	2.215	56.26	TL08-212/70MM	8434241809
2-13/16"		#6	2.332	59.23	TL08-213	8434242580
2-15/16"	75	#6	2.332	59.23	TL08-215/75MM	8434241810
3"		#7	2.445	62.10	TL08-300	8434242581
	77	#7	2.445	62.10	TL08-77MM	8434242582
3-1/16"	78	#7	2.445	62.10	TL08-78MM	8434242583
3-1/8"	80	#7	2.445	62.10	TL08-302/80MM	8434242584
	85	#8	2.567	65.20	TL08-85MM	8434241812
3-3/8"		#8	2.567	65.20	TL08-306	8434242585
3-1/2"		#9	2.673	67.89	TL08-308	8434241813
	90	#9	2.673	67.89	TL08-90MM	8434241814
3-5/8"		#10	2.797	71.04	TL08-310	8434242586
3-3/4"	95	#10	2.797	71.04	TL08-312/95MM	8434241815
3-7/8"		#11	2.900	73.66	TL08-314	8434241816
	100	#11	2.900	73.66	TL08-100MM	8434241817

Additional ratchet link sizes available upon request.

TFX14 Ratchet link sizes

Nominal Hexagon A/F Inch	Metric	Link Ref.	Nose Radius 'R' [in] (Decimal)	Nose Radius 'R' [mm] (Decimal)	Model	Ordering No.
1-1/4"	32	#1	2.331	59.21	TL14-104/32MM	8434242587
1-1/2"		#1	2.331	59.21	TL14-108	8434242588
1-9/16"		#1	2.331	59.21	TL14-109	8434242589
1-5/8"	41	#1	2.331	59.21	TL14-110/41MM	8434242590
1-11/16"		#1	2.331	59.21	TL14-111	8434242591
1-3/4"		#1	2.331	59.21	TL14-112	8434242592
1-13/16"	46	#1	2.331	59.21	TL14-113/46MM	8434242593
1-7/8"		#1	2.331	59.21	TL14-114	8434242594
2"	50	#1	2.331	59.21	TL14-50MM	8434242595
2-3/16"	55	#1	2.331	59.21	TL14-203/55MM	8434242596
2-1/4"		#1	2.331	59.21	TL14-204	8434242598
2-3/8"	60	#1	2.331	59.21	TL14-206/60MM	8434242599
2-1/2"		#1	2.331	59.21	TL14-208	8434242600
2-9/16"	65	#1	2.331	59.21	TL14-209/65MM	8434242601
2-5/8"		#1	2.331	59.21	TL14-210	8434242602
2-3/4"	70	#1	2.331	59.21	TL14-212/70MM	8434242134
2-13/16"		#2	2.447	62.15	TL14-213	8434242603
2-15/16"	75	#2	2.447	62.15	TL14-215/75MM	8434242135
3"		#3	2.561	65.05	TL14-300	8434242604
	77	#3	2.561	65.05	TL14-77MM	8434242605
3-1/16"	78	#3	2.561	65.05	TL14-301	8434242606
3-1/8"	80	#3	2.561	65.05	TL14-302/80MM	8434242136
3-3/16"		#4	2.682	68.12	TL14-303	8434242607
	85	#4	2.682	68.12	TL14-85MM	8434242137
3-3/8"		#4	2.682	68.12	TL14-306	8434242608
3-1/2"		#5	2.788	70.82	TL14-308	8434242138
	90	#5	2.788	70.82	TL14-90MM	8434242139
3-5/8"		#6	2.913	73.99	TL14-310	8434242609
3-11/16"		#6	2.913	73.99	TL14-311	8434242610
3-3/4"	95	#6	2.913	73.99	TL14-312/95MM	8434242140
3-7/8"		#7	3.015	76.58	TL14-314	8434242141
	100	#7	3.015	76.58	TL14-100MM	8434242142
4-1/16"		#8	3.132	79.55	TL14-401	8434242611
4-1/8"		#8	3.132	79.55	TL14-402	8434242612
	105	#8	3.132	79.55	TL14-105MM	8434242143
4-3/16"		#9	3.246	82.45	TL14-403	8434242613
4-1/4"		#9	3.246	82.45	TL14-404	8434242144
	110	#9	3.246	82.45	TL14-110MM	8434242145
4-1/2"		#10	3.473	88.20	TL14-408	8434242614
	115	#10	3.473	88.20	TL14-115MM	8434242146
4-5/8"		#10	3.473	88.20	TL14-410	8434242147
	120	#10	3.473	88.20	TL14-120MM	8434242148

Additional ratchet link sizes available upon request.

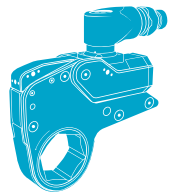

TFX18 Ratchet link sizes

Nominal Hexagon A/F Inch	Metric	Link Ref.	Nose Radius 'R' [in] (Decimal)	Nose Radius 'R' [mm] (Decimal)	Model	Ordering No.
2-3/16"	55	#1	2.572	65.32	TL18-203/55MM	8434242615
2-1/4"		#1	2.572	65.32	TL-204	8434242616
2-3/8"	60	#1	2.572	65.32	TL18-206/60MM	8434242617
2-1/2"		#1	2.572	65.32	TL18-208	8434242618
2-9/16"	65	#1	2.572	65.32	TL18-209/65MM	8434242619
2-5/8"		#1	2.572	65.32	TL18-210	8434242620
2-3/4"	70	#1	2.572	65.32	TL18-212/70MM	8434242456
2-13/16"		#1	2.572	65.32	TL18-213	8434242621
2-15/16"	75	#1	2.572	65.32	TL18-215/75MM	8434242457
3"		#1	2.572	65.32	TL18-300	8434242622
	77	#2	2.685	68.20	TL18-77MM	8434242623
3-1/16"	78	#2	2.685	68.20	TL18-301	8434242624
3-1/8"	80	#2	2.685	68.20	TL18-302/80MM	8434242458
3-3/16"		#3	2.913	73.98	TL18-303	8434242625
	85	#3	2.913	73.98	TL18-85MM	8434242459
3-3/8"		#3	2.913	73.98	TL18-306	8434242626
3-1/2"		#3	2.913	73.98	TL18-308	8434242460
	90	#3	2.913	73.98	TL18-90MM	8434242461
3-5/8"		#4	3.140	79.74	TL18-310	8434242627
3-11/16"		#4	3.140	79.74	TL18-311	8434242628
3-3/4"	95	#4	3.140	79.74	TL18-312/95MM	8434242462
3-7/8"		#4	3.140	79.74	TL18-314	8434242463
	100	#4	3.140	79.74	TL18-100MM	8434242464
4-1/16"		#5	3.371	85.61	TL18-401	8434242629
4-1/8"		#5	3.371	85.61	TL18-402	8434242630
	105	#5	3.371	85.61	TL18-105MM	8434242465
4-3/16"		#5	3.371	85.61	TL18-403	8434242631
4-1/4"		#5	3.371	85.61	TL18-404	8434242466
	110	#5	3.371	85.61	TL18-110MM	8434242467
4-1/2"		#6	3.598	91.39	TL18-408	8434242632
	115	#6	3.598	91.39	TL18-115MM	8434242468
4-5/8"		#6	3.598	91.39	TL18-410	8434242469
	120	#7	3.816	96.91	TL18-120MM	8434242470
5"		#7	3.816	96.91	TL18-500	8434242471
	130	#8	3.985	101.22	TL18-130MM	8434242472
	135	#8	3.985	101.22	TL18-135MM	8434242473
5-3/8"		#8	3.985	101.22	TL18-506	8434242474

Additional ratchet link sizes available upon request.

TFX30 Ratchet link sizes

Nominal Hexagon A/F Inch	Metric	Link Ref.	Nose Radius 'R' [in] (Decimal)	Nose Radius 'R' [mm] (Decimal)	Model	Ordering No.
2-9/16"	65	#1	3.029	76.94	TL30-209/65MM	8434242633
2-5/8"		#1	3.029	76.94	TL30-210	8434242634
2-3/4"	70	#1	3.029	76.94	TL30-212/70MM	8434242635
2-13/16"		#1	3.029	76.94	TL30-213	8434242636
2-15/16"	75	#1	3.029	76.94	TL30-215/75MM	8434242637
3"		#1	3.029	76.94	TL30-300	8434242638
	77	#1	3.029	76.94	TL30-77MM	8434242639
3-1/16"	78	#1	3.029	76.94	TL30-301	8434242640
3-1/8"	80	#1	3.029	76.94	TL30-302/80MM	8434242641
3-3/16"		#1	3.029	3.029	TL30-303	8434242642
	85	#1	3.029	76.94	TL30-85MM	8434242475
3-3/8"		#1	3.029	76.94	TL30-306	8434242643
3-1/2"		#1	3.029	76.94	TL30-308	8434242476
	90	#2	3.256	82.70	TL30-90MM	8434242477
3-5/8"		#2	3.256	82.70	TL30-310	8434242644
3-11/16"		#2	3.256	82.70	TL30-311	8434242645
3-3/4"	95	#2	3.256	82.70	TL30-312/95MM	8434242478
3-7/8"		#2	3.256	82.70	TL30-314	8434242479
	100	#2	3.256	82.70	TL30-100MM	8434242480
4-1/16"		#3	3.487	88.57	TL30-401	8434242646
4-1/8"		#3	3.487	88.57	TL30-402	8434242647
	105	#3	3.487	88.57	TL30-105MM	8434242481
4-3/16"		#3	3.487	88.57	TL30-403	8434242648
4-1/4"		#3	3.487	88.57	TL30-404	8434242482
	110	#3	3.487	88.57	TL30-110MM	8434242483
4-1/2"		#4	3.713	94.31	TL30-408	8434242649
	115	#4	3.713	94.31	TL30-115MM	8434242484
4-5/8"		#4	3.713	94.31	TL30-410	8434242485
	120	#5	3.941	100.10	TL30-120MM	8434242486
5"		#5	3.941	100.10	TL30-500	8434242487
	130	#6	4.101	104.17	TL30-130MM	8434242488
	135	#6	4.101	104.17	TL30-135MM	8434242489
5-3/8"		#6	4.101	104.17	TL30-506	8434242490
	140	#7	4.320	109.73	TL30-140MM	8434242650
	145	#7	4.320	109.73	TL30-145MM	8434242491
5-3/4"		#7	4.320	109.73	TL30-512	8434242492
	150	#8	4.537	115.24	TL30-150MM	8434242651
5-15/16"		#8	4.537	115.24	TL30-515	8434242652
6-1/8"	155	#8	4.537	115.24	TL30-602/155MM	8434242493

Additional ratchet link sizes available upon request.

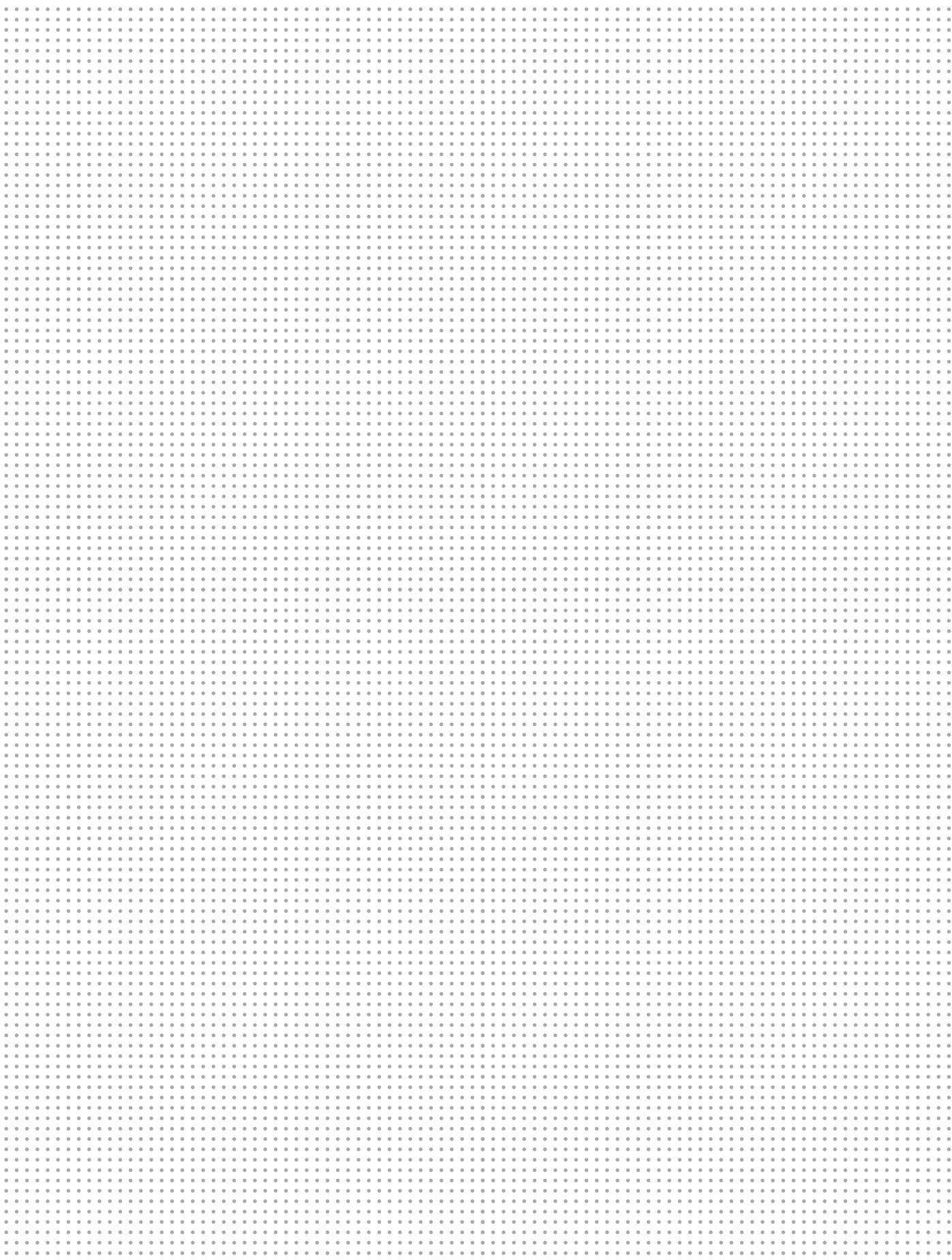

EA Tool

Extreme access spanner

The EA Tool is perfect for ultra-tight clearances where our reduced-radius ratchet links for RTX/ TFX series won't fit. To choose the best one for your application, follow these steps:

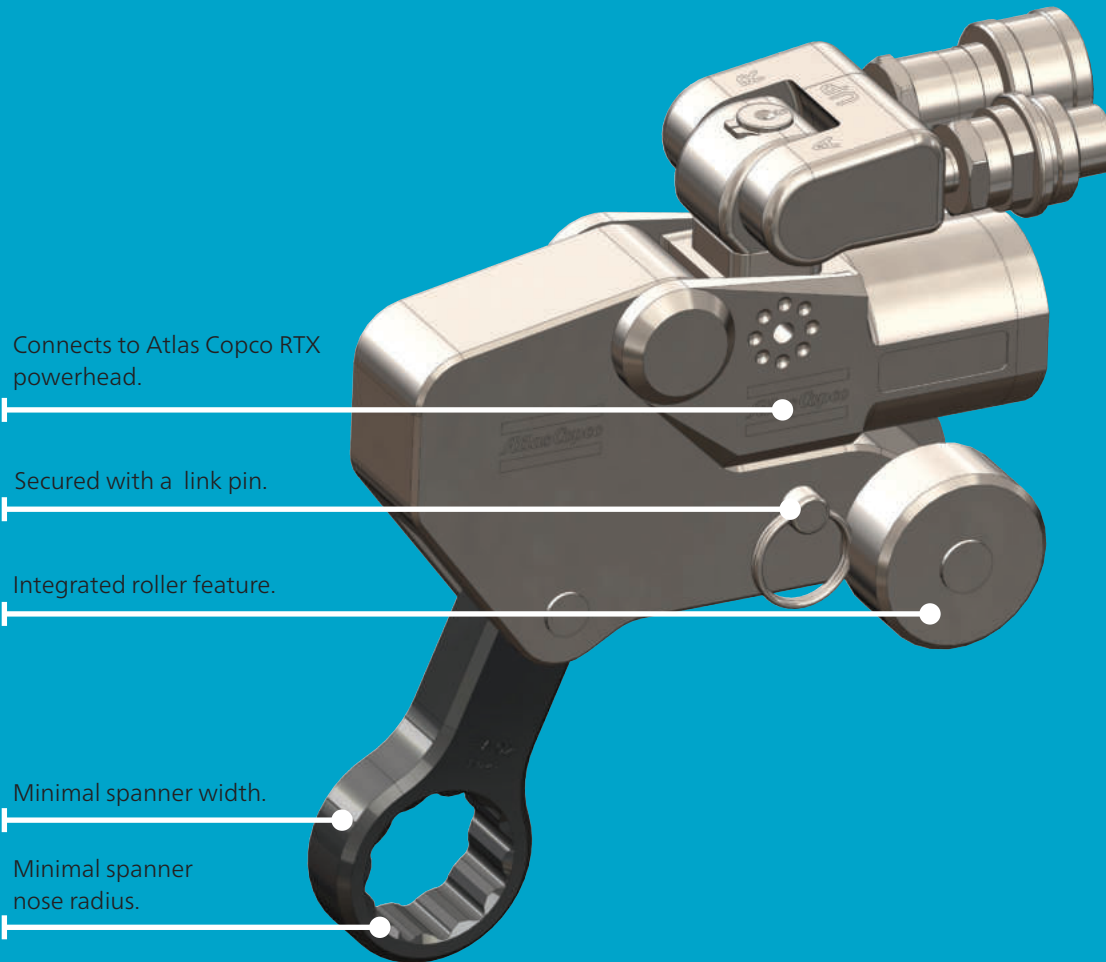

Choose your power head

The RTX/TFX powers the EA Spanner assembly. Choose your powerhead based on the torque values you will need.



Set up your link

Our link has been designed from the ground up to provide the strength needed while being extremely easy to set up.



Choose your spanner

Extreme Access spanners provide the durability and strength of our traditional ratchet links but can fit where traditional links won't.

EA Spanner ordering numbers



Ordering No.	Model No.	Size/Dimension.
EA02 SPANNERS		
8434216513	EA02-012/19MM	3/4" / 19mm
8434216514	EA02-013	13/16"
8434216515	EA02-014/22MM	7/8" / 22mm
8434216517	EA02-015/24MM	15/16" / 24mm
8434216518	EA02-100	1"
8434216519	EA02-101/27MM	1-1/16" / 27mm
8434216520	EA02-102	1-1/8"
8434216521	EA02-103/30MM	1-3/16" / 30mm
8434216523	EA02-104/32MM	1-1/4" / 32mm
8434216524	EA02-105	1-5/16"
8434216525	EA02-106	1-3/8"
8434216527	EA02-107/36MM	1-7/16" / 36mm
8434216528	EA02-108	1-1/2"
8434216529	EA02-109	1-9/16"
8434216530	EA02-110/41MM	1-5/8" / 41mm
8434216532	EA02-42MM	42mm
8434216533	EA02-111	1-11/16"
8434216534	EA02-112	1-3/4"
8434216535	EA02-113/46MM	1-13/16" / 46mm
8434216536	EA02-114	1-7/8"
8434216537	EA02-115	1-15/16"
8434202204	EA02-50MM	50mm
8434216538	EA02-200	2"
8434216539	EA02-201	2-1/16"
8434216540	EA02-202	2-1/8"
8434216541	EA02-203/55MM	2-3/16" / 55mm
8434216543	EA02-204	2-1/4"
8434216544	EA02-205	2-5/16"
8434216545	EA02-206/60MM	2-3/8" / 60mm
8434216547	EA02-207	2-7/16"
8434216548	EA02-208	2-1/2"
8434216549	EA02-209/65MM	2-9/16" / 65mm
8434216550	EA02-210	2-5/8"
8434216551	EA02-211	2-11/16"
8434216553	EA02-212/70MM	2-3/4" / 70mm
8434216554	EA02-213	2-13/16"
8434216555	EA02-214	2-7/8"
8434216557	EA02-215/75MM	2-15/16" / 75mm

Ordering No.	Model No.	Size/Dimension.
EA04 SPANNERS		
8434216560	EA04-104/32MM	1-1/4" / 32mm
8434216561	EA04-105	1-5/16"
8434216562	EA04-106	1-3/8"
8434216564	EA04-107/36MM	1-7/16" / 36mm
8434216565	EA04-108	1-1/2"
8434216566	EA04-109	1-9/16"
8434216568	EA04-110/41MM	1-5/8" / 41mm
8434216570	EA04-111	1-11/16"
8434216571	EA04-112	1-3/4"
8434216572	EA04-113/46MM	1-13/16" / 46mm
8434216573	EA04-114	1-7/8"
8434216574	EA04-115	1-15/16"
8434216575	EA04-50MM	50mm
8434216576	EA04-200	2"
8434216577	EA04-51MM	51mm
8434202301	EA04-201	2-1/16"
8434216578	EA04-202	2-1/8"
8434216579	EA04-203/55MM	2-3/16" / 55mm
8434216580	EA04-56MM	56mm
8434216581	EA04-204	2-1/4"
8434216582	EA04-205	2-5/16"
8434216583	EA04-206/60MM	2-3/8" / 60mm
8434216584	EA04-61MM	61mm
8434216585	EA04-207	2-7/16"
8434216586	EA04-208	2-1/2"
8434202197	EA04-209/65MM	2-9/16" / 65mm
8434216587	EA04-66MM	66mm
8434216588	EA04-210	2-5/8"
8434216589	EA04-211	2-11/16"
8434216590	EA04-212/70MM	2-3/4" / 70mm
8434216592	EA04-213	2-13/16"
8434216593	EA04-214	2-7/8"
8434216594	EA04-215/75MM	2-15/16" / 75mm
8434216595	EA04-300	3"
8434216596	EA04-302/80MM	3-1/8" / 80mm

Ordering No.	Model No.	Size/Dimension.
EA08 SPANNERS		
8434216605	EA08-113/46MM	1-13/16" / 46mm
8434216606	EA08-114	1-7/8"
8434216607	EA08-115	1-15/16"
8434216608	EA08-50MM	50mm
8434216609	EA08-200	2"
8434216610	EA08-51MM	51mm
8434216611	EA08-201	2-1/16"
8434216612	EA08-202	2-1/8"
8434216614	EA08-203/55MM	2-3/16" / 55mm
8434216615	EA08-56MM	56mm
8434216616	EA08-204	2-1/4"
8434216617	EA08-205	2-5/16"
8434216619	EA08-206/60MM	2-3/8" / 60mm
8434216620	EA08-61MM	61mm
8434216621	EA08-207	2-7/16"
8434216622	EA08-208	2-1/2"
8434216623	EA08-209/65MM	2-9/16" / 65mm
8434216624	EA08-66MM	66mm
8434216625	EA08-210	2-5/8"
8434216626	EA08-211	2-11/16"
8434216628	EA08-212/70MM	2-3/4" / 70mm
8434216629	EA08-71MM	71mm
8434216630	EA08-213	2-13/16"
8434216631	EA08-214	2-7/8"
8434216633	EA08-215/75MM	2-15/16" / 75mm
8434216634	EA08-300	3"
8434216636	EA08-302/80MM	3-1/8" / 80mm
8434202203	EA08-304	3-1/4"
8434216637	EA08-305	3-5/16"
8434216638	EA08-306 / 85MM	3-3/8" / 85mm
8434216640	EA08-308	3-1/2"
8434216641	EA08-90MM	90mm
8434216642	EA08-309	3-9/16"
8434216643	EA08-312 / 95MM	3-3/4" / 95mm
8434216644	EA08-314	3-7/8"
8434202024	EA08-100MM	100mm

Low profile hydraulic torque wrench accessories

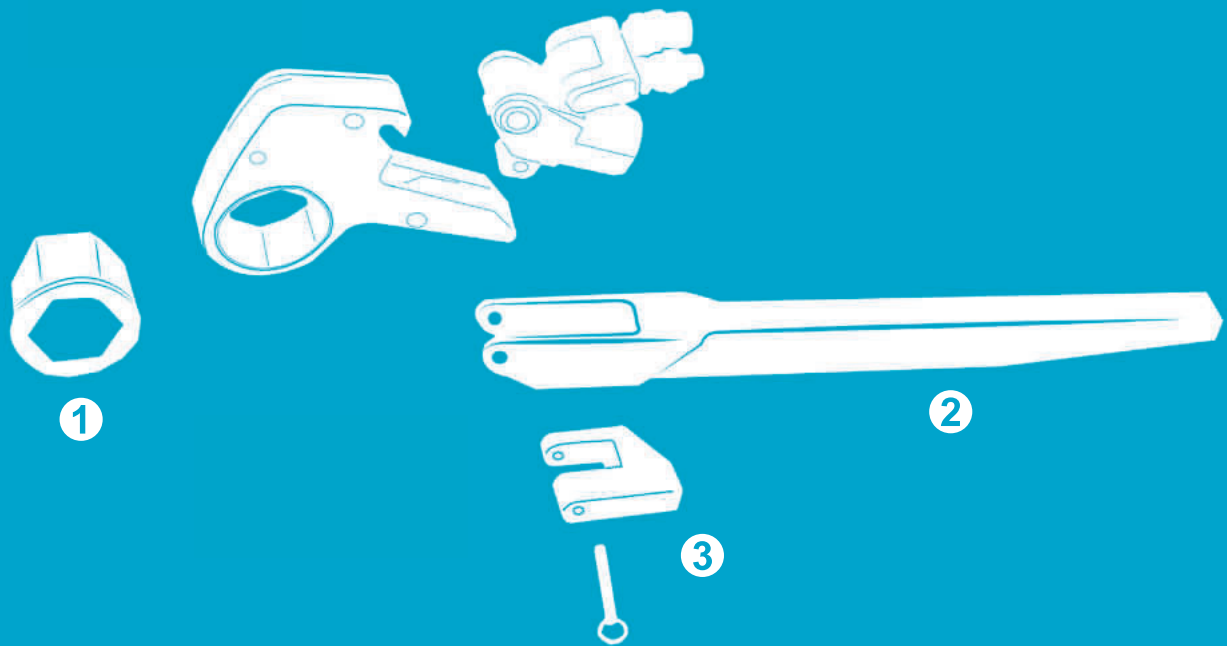

- ① Insert hex reducer
- ② Alco arm
- ③ Onside reaction arm

TFX Tool accessories

1 Insert hex reducer



Please see put selection of hex reducers on the following page.

2 Alco arm



Model	Ordering No.
RTX02-ALC	8434 2057 58
RTX04-ALC	8434 2057 60
RTX08-ALC	8434 2057 62
RTX14-ALC	8434 2057 64
RTX18-ALC	8434 2057 66
RTX30-ALC	8434 2057 67

3 Onside reaction arm



Model	Ordering No.
RTX02-14	4222 2107 14
RTX04-14	4222 2109 27
RTX08-14	4222 2110 44
RTX14-14	4222 2141 22
RTX18-14	4222 2141 23
RTX30-14	4222 2144 43

Custom sizes available on request



Insert Hex Reducer ordering numbers

Ordering No.	Assy Description	Size	
		Inch	mm
4222907694	INS HEX RED. RTX02-INS-110/107	1 5/8 - 1 7/16	41 - 36
4222210166	INS HEX RED. RTX02-INS-110/104	1 5/8 - 1 1/4	41 - 32
4222213851	INS HEX RED. RTX02-INS-113/110	1 13/16 - 1 5/8	46 - 41
4222213426	INS HEX RED. RTX02-INS-113/107	1 13/16 - 1 7/16	46 - 36
4222213853	INS HEX RED. RTX02-INS-113/104	1 13/16 - 1 1/4	46 - 32
4222213432	INS HEX RED. RTX02-INS-050/046	-	50 - 46
4222213429	INS HEX RED. RTX02-INS-050/041	-	50 - 41
4222907695	INS HEX RED. RTX02-INS-050/036	-	50 - 36
4222907696	INS HEX RED. RTX02-INS-200/113	2 - 1 13/16	-
4222907697	INS HEX RED. RTX02-INS-200/110	2 - 1 5/8	-
4222907698	INS HEX RED. RTX02-INS-200/107	2 - 1 7/16	-
4222213410	INS HEX RED. RTX02-INS-203/200	2 3/16 - 2	55 - 50
4222213875	INS HEX RED. RTX02-INS-203/113	2 3/16 - 1 13/16	55 - 46
4222213436	INS HEX RED. RTX02-INS-203/110	2 3/16 - 1 5/8	55 - 41
4222907699	INS HEX RED. RTX02-INS-206/203	2 3/8 - 2 3/16	60 - 55
4222907700	INS HEX RED. RTX02-INS-206/200	2 3/8 - 2	60 - 50
4222907701	INS HEX RED. RTX02-INS-206/113	2 3/8 - 1 13/16	60 - 46
4222213434	INS HEX RED. RTX02-INS-209/206	2 9/16 - 2 3/8	65 - 60
4222213433	INS HEX RED. RTX02-INS-209/203	2 9/16 - 2 3/16	65 - 55
4222907702	INS HEX RED. RTX02-INS-209/200	2 9/16 - 2	65 - 50
4222907721	INS HEX RED. RTX02-INS-110/103	1 5/8 - 1 3/16	41 - 30
4222907777	INS HEX RED. RTX04-INS-110/107	1 5/8 - 1 7/16	41 - 36
4222234566	INS HEX RED. RTX04-INS-110/104	1 5/8 - 1 1/4	41 - 32
4222907778	INS HEX RED. RTX04-INS-113/110	1 13/16 - 1 5/8	46 - 41
4222211962	INS HEX RED. RTX04-INS-113/107	1 13/16 - 1 7/16	46 - 36
4222907779	INS HEX RED. RTX04-INS-113/104	1 13/16 - 1 1/4	46 - 32
4222213840	INS HEX RED. RTX04-INS-050/046	-	50 - 46
4222213834	INS HEX RED. RTX04-INS-050/041	-	50 - 41
4222213860	INS HEX RED. RTX04-INS-050/036	-	50 - 36
4222213777	INS HEX RED. RTX04-INS-200/113	2 - 1 13/16	-
4222907780	INS HEX RED. RTX04-INS-200/110	2 - 1 5/8	-
4222907781	INS HEX RED. RTX04-INS-200/107	2 - 1 7/16	-
4222213843	INS HEX RED. RTX04-INS-203/200	2 3/16 - 2	55 - 50
4222213842	INS HEX RED. RTX04-INS-203/113	2 3/16 - 1 13/16	55 - 46
4222213841	INS HEX RED. RTX04-INS-203/110	2 3/16 - 1 5/8	55 - 41
4222213832	INS HEX RED. RTX04-INS-206/203	2 3/8 - 2 3/16	60 - 55
4222213827	INS HEX RED. RTX04-INS-206/200	2 3/8 - 2	60 - 50
4222213830	INS HEX RED. RTX04-INS-206/113	2 3/8 - 1 13/16	60 - 46
4222211975	INS HEX RED. RTX04-INS-209/206	2 9/16 - 2 3/8	65 - 60
4222211974	INS HEX RED. RTX04-INS-209/203	2 9/16 - 2 3/16	65 - 55
4222907782	INS HEX RED. RTX04-INS-209/200	2 9/16 - 2	-
4222211982	INS HEX RED. RTX04-INS-212/209	2 3/4 - 2 9/16	70 - 65
4222213804	INS HEX RED. RTX04-INS-212/206	2 3/4 - 2 3/8	70 - 60
4222213798	INS HEX RED. RTX04-INS-212/203	2 3/4 - 2 3/16	70 - 55
4222907783	INS HEX RED. RTX04-INS-215/212	2 15/16 - 2 3/4	75 - 70

Insert Hex Reducer ordering numbers

Ordering No.	Assy Description	Size	
		Inch	mm
4222213807	INS HEX RED. RTX04-INS-215/209	2 15/16 - 2 9/16	75 - 65
4222907784	INS HEX RED. RTX04-INS-215/206	2 15/16 - 2 3/8	75 - 60
4222213857	INS HEX RED. RTX04-INS-302/215	3 1/8 - 2 15/16	80 - 75
4222213826	INS HEX RED. RTX04-INS-302/212	3 1/8 - 2 3/4	80 - 70
4222213859	INS HEX RED. RTX04-INS-302/209	3 1/8 - 2 9/16	80 - 65
4222212211	INS HEX RED. RTX08-INS-206/203	2 3/8 - 2 3/16	60 - 55
4222212207	INS HEX RED. RTX08-INS-206/200	2 3/8 - 2	60 - 50
4222212206	INS HEX RED. RTX08-INS-206/113	2 3/8 - 1 13/16	60 - 46
4222212212	INS HEX RED. RTX08-INS-209/206	2 9/16 - 2 3/8	65 - 60
4222212213	INS HEX RED. RTX08-INS-209/203	2 9/16 - 2 3/16	65 - 55
4222214081	INS HEX RED. RTX08-INS-209/200	2 9/16 - 2	65 - 50
4222214089	INS HEX RED. RTX08-INS-212/209	2 3/4 - 2 9/16	70 - 65
4222907786	INS HEX RED. RTX08-INS-212/206	2 3/4 - 2 3/8	70 - 60
4222214086	INS HEX RED. RTX08-INS-212/203	2 3/4 - 2 3/16	70 - 55
4222214090	INS HEX RED. RTX08-INS-215/212	2 15/16 - 2 3/4	75 - 70
4222907787	INS HEX RED. RTX08-INS-215/209	2 15/16 - 2 9/16	75 - 65
4222214091	INS HEX RED. RTX08-INS-215/206	2 15/16 - 2 3/8	75 - 60
4222214068	INS HEX RED. RTX08-INS-302/215	3 1/8 - 2 15/16	80 - 75
4222907788	INS HEX RED. RTX08-INS-302/212	3 1/8 - 2 3/4	80 - 70
4222214098	INS HEX RED. RTX08-INS-302/209	3 1/8 - 2 9/16	80 - 65
4222907789	INS HEX RED. RTX08-INS-306/302	3 3/8 - 3 1/8	85 - 80
4222907790	INS HEX RED. RTX08-INS-306/215	3 3/8 - 2 15/16	85 - 75
4222907791	INS HEX RED. RTX08-INS-306/212	3 3/8 - 2 3/4	85 - 70
4222907792	INS HEX RED. RTX08-INS-308/306	3 1/2 - 3 3/8	-
4222907793	INS HEX RED. RTX08-INS-308/302	3 1/2 - 3 1/8	-
4222907794	INS HEX RED. RTX08-INS-308/215	3 1/2 - 2 15/16	-
4222907795	INS HEX RED. RTX08-INS-090/085	-	90 - 85
4222907796	INS HEX RED. RTX08-INS-090/080	-	90 - 80
4222907797	INS HEX RED. RTX08-INS-090/075	-	90 - 75
4222907798	INS HEX RED. RTX08-INS-095/090	-	95 - 90
4222907799	INS HEX RED. RTX08-INS-312/306	3 3/4 - 3 3/8	95 - 85
4222214104	INS HEX RED. RTX08-INS-312/302	3 3/4 - 3 1/8	95 - 80
4222907800	INS HEX RED. RTX08-INS-314/312	3 7/8 - 3 3/4	-
4222214080	INS HEX RED. RTX08-INS-314/308	3 7/8 - 3 1/2	-
4222907801	INS HEX RED. RTX08-INS-314/306	3 7/8 - 3 3/8	-
4222907802	INS HEX RED. RTX08-INS-100/095	-	100 - 95
4222907803	INS HEX RED. RTX08-INS-100/090	-	100 - 90
4222907804	INS HEX RED. RTX08-INS-100/085	-	100 - 85
4222907839	INS HEX RED. RTX14-INS-212/209	2 3/4 - 2 9/16	70 - 65
4222907840	INS HEX RED. RTX14-INS-212/206	2 3/4 - 2 3/8	70 - 60
4222907841	INS HEX RED. RTX14-INS-212/203	2 3/4 - 2 3/16	70 - 55
4222907842	INS HEX RED. RTX14-INS-215/212	2 15/16 - 2 3/4	75 - 70
4222907843	INS HEX RED. RTX14-INS-215/209	2 15/16 - 2 9/16	75 - 65
4222907844	INS HEX RED. RTX14-INS-215/206	2 15/16 - 2 3/8	75 - 60
4222907845	INS HEX RED. RTX14-INS-302/215	3 1/8 - 2 15/16	80 - 75



Insert Hex Reducer ordering numbers

Ordering No.	Assy Description	Size	
		Inch	mm
4222214339	INS HEX RED. RTX14-INS-302/212	3 1/8 - 2 3/4	80 - 70
4222907846	INS HEX RED. RTX14-INS-302/209	3 1/8 - 2 9/16	80 - 65
4222907847	INS HEX RED. RTX14-INS-306/302	3 3/8 - 3 1/8	85 - 80
4222907848	INS HEX RED. RTX14-INS-306/215	3 3/8 - 2 15/16	85 - 75
4222907849	INS HEX RED. RTX14-INS-306/212	3 3/8 - 2 3/4	85 - 70
4222907850	INS HEX RED. RTX14-INS-308/306	3 1/2 - 3 3/8	-
4222907851	INS HEX RED. RTX14-INS-308/302	3 1/2 - 3 1/8	-
4222907852	INS HEX RED. RTX14-INS-308/215	3 1/2 - 2 15/16	-
4222907853	INS HEX RED. RTX14-INS-090/085	-	90 - 85
4222907854	INS HEX RED. RTX14-INS-090/080	-	90 - 80
4222210152	INS HEX RED. RTX14-INS-090/075	-	90 - 75
4222907855	INS HEX RED. RTX14-INS-095/090	-	95 - 90
4222907856	INS HEX RED. RTX14-INS-312/306	3 3/4 - 3 3/8	95 - 85
4222907857	INS HEX RED. RTX14-INS-312/302	3 3/4 - 3 1/8	95 - 80
4222907858	INS HEX RED. RTX14-INS-314/312	3 7/8 - 3 3/4	-
4222214338	INS HEX RED. RTX14-INS-314/308	3 7/8 - 3 1/2	-
4222907859	INS HEX RED. RTX14-INS-314/306	3 7/8 - 3 3/8	-
4222210179	INS HEX RED. RTX14-INS-100/095	-	100 - 95
4222210164	INS HEX RED. RTX14-INS-100/090	-	100 - 90
4222907860	INS HEX RED. RTX14-INS-100/085	-	100 - 85
4222907861	INS HEX RED. RTX14-INS-105/100	-	105 - 100
4222907862	INS HEX RED. RTX14-INS-105/095	-	105 - 95
4222907863	INS HEX RED. RTX14-INS-105/090	-	105 - 90
4222907864	INS HEX RED. RTX14-INS-404/314	4 1/4 - 3 7/8	-
4222907865	INS HEX RED. RTX14-INS-404/312	4 1/4 - 3 3/4	-
4222907866	INS HEX RED. RTX14-INS-404/308	4 1/4 - 3 1/2	-
4222907867	INS HEX RED. RTX14-INS-110/105	-	110 - 105
4222907868	INS HEX RED. RTX14-INS-110/100	-	110 - 100
4222907869	INS HEX RED. RTX14-INS-110/095	-	110 - 95
4222210176	INS HEX RED. RTX14-INS-115/110	-	115 - 110
4222210178	INS HEX RED. RTX14-INS-115/105	-	115 - 105
4222907870	INS HEX RED. RTX14-INS-115/100	-	115 - 100
4222214344	INS HEX RED. RTX14-INS-410/404	4 5/8 - 4 1/4	-
4222214341	INS HEX RED. RTX14-INS-410/314	4 5/8 - 3 7/8	-
4222907871	INS HEX RED. RTX14-INS-410/312	4 5/8 - 3 3/4	-
4222907872	INS HEX RED. RTX14-INS-120/115	-	120 - 115
4222907873	INS HEX RED. RTX14-INS-120/110	-	120 - 110
4222907874	INS HEX RED. RTX14-INS-120/105	-	120 - 105
4222907397	INS HEX RED. RTX18-INS-212/209	2 3/4 - 2 9/16	70 - 65
4222907398	INS HEX RED. RTX18-INS-212/206	2 3/4 - 2 3/8	70 - 60
4222907399	INS HEX RED. RTX18-INS-212/203	2 3/4 - 2 3/16	70 - 55
4222907400	INS HEX RED. RTX18-INS-215/212	2 15/16 - 2 3/4	75 - 70
4222907403	INS HEX RED. RTX18-INS-215/209	2 15/16 - 2 9/16	75 - 65
4222907404	INS HEX RED. RTX18-INS-215/206	2 15/16 - 2 3/8	75 - 60
4222907405	INS HEX RED. RTX18-INS-302/215	3 1/8 - 2 15/16	80 - 75

Insert Hex Reducer ordering numbers

Ordering No.	Assy Description	Size	
		Inch	mm
4222907406	INS HEX RED. RTX18-INS-302/212	3 1/8 - 2 3/4	80 - 70
4222907408	INS HEX RED. RTX18-INS-302/209	3 1/8 - 2 9/16	80 - 65
4222907409	INS HEX RED. RTX18-INS-306/302	3 3/8 - 3 1/8	85 - 80
4222907411	INS HEX RED. RTX18-INS-306/215	3 3/8 - 2 15/16	85 - 75
4222907412	INS HEX RED. RTX18-INS-306/212	3 3/8 - 2 3/4	85 - 70
4222907413	INS HEX RED. RTX18-INS-308/306	3 1/2 - 3 3/8	-
4222907414	INS HEX RED. RTX18-INS-308/302	3 1/2 - 3 1/8	-
4222907416	INS HEX RED. RTX18-INS-308/215	3 1/2 - 2 15/16	-
4222907418	INS HEX RED. RTX18-INS-090/085	-	90 - 85
4222907419	INS HEX RED. RTX18-INS-090/080	-	90 - 80
4222907420	INS HEX RED. RTX18-INS-090/075	-	90 - 75
4222907421	INS HEX RED. RTX18-INS-095/090	-	95 - 90
4222907423	INS HEX RED. RTX18-INS-312/306	3 3/4 - 3 3/8	95 - 85
4222907424	INS HEX RED. RTX18-INS-312/302	3 3/4 - 3 1/8	95 - 80
4222907425	INS HEX RED. RTX18-INS-314/312	3 7/8 - 3 3/4	-
4222907426	INS HEX RED. RTX18-INS-314/308	3 7/8 - 3 1/2	-
4222907427	INS HEX RED. RTX18-INS-314/306	3 7/8 - 3 3/8	-
4222907428	INS HEX RED. RTX18-INS-100/095	-	100 - 95
4222907429	INS HEX RED. RTX18-INS-100/090	-	100 - 90
4222907430	INS HEX RED. RTX18-INS-100/085	-	100 - 85
4222907431	INS HEX RED. RTX18-INS-105/100	-	105 - 100
4222907432	INS HEX RED. RTX18-INS-105/095	-	105 - 95
4222907433	INS HEX RED. RTX18-INS-105/090	-	105 - 90
4222907434	INS HEX RED. RTX18-INS-404/314	4 1/4 - 3 7/8	-
4222907435	INS HEX RED. RTX18-INS-404/312	4 1/4 - 3 3/4	-
4222907436	INS HEX RED. RTX18-INS-404/308	4 1/4 - 3 1/2	-
4222907437	INS HEX RED. RTX18-INS-110/105	-	110 - 105
4222907438	INS HEX RED. RTX18-INS-110/100	-	110 - 100
4222907439	INS HEX RED. RTX18-INS-110/095	-	110 - 95
4222907440	INS HEX RED. RTX18-INS-115/110	-	115 - 110
4222907441	INS HEX RED. RTX18-INS-115/105	-	115 - 105
4222907442	INS HEX RED. RTX18-INS-115/100	-	115 - 100
4222907443	INS HEX RED. RTX18-INS-410/404	4 5/8 - 4 1/4	-
4222907444	INS HEX RED. RTX18-INS-410/314	4 5/8 - 3 7/8	-
4222214422	INS HEX RED. RTX18-INS-410/312	4 5/8 - 3 3/4	-
4222907445	INS HEX RED. RTX18-INS-120/115	-	120 - 115
4222907446	INS HEX RED. RTX18-INS-120/110	-	120 - 110
4222907447	INS HEX RED. RTX18-INS-120/105	-	120 - 105
4222907448	INS HEX RED. RTX18-INS-500/410	5 - 4 5/8	-
4222907449	INS HEX RED. RTX18-INS-500/404	5 - 4 1/4	-
4222907450	INS HEX RED. RTX18-INS-500/314	5 - 3 7/8	-
4222907451	INS HEX RED. RTX18-INS-130/120	-	130 - 120
4222907452	INS HEX RED. RTX18-INS-130/115	-	130 - 115
4222907453	INS HEX RED. RTX18-INS-130/110	-	130 - 110
4222907454	INS HEX RED. RTX18-INS-135/130	-	135 - 130



Insert Hex Reducer ordering numbers

Ordering No.	Assy Description	Size	
		Inch	mm
4222907455	INS HEX RED. RTX18-INS-135/120	-	135 - 120
4222907456	INS HEX RED. RTX18-INS-135/115	-	135 - 115
4222907457	INS HEX RED. RTX18-INS-506/500	5 3/8 - 5	-
4222907458	INS HEX RED. RTX18-INS-506/410	5 3/8 - 4 5/8	-
4222907459	INS HEX RED. RTX18-INS-506/404	5 3/8 - 4 1/4	-
4222907970	INS HEX RED. RTX30-INS-302/215	3 1/8 - 2 15/16	80 - 75
4222907971	INS HEX RED. RTX30-INS-302/212	3 1/8 - 2 3/4	80 - 70
4222907972	INS HEX RED. RTX30-INS-302/209	3 1/8 - 2 9/16	80 - 65
4222907973	INS HEX RED. RTX30-INS-306/302	3 3/8 - 3 1/8	85 - 80
4222907974	INS HEX RED. RTX30-INS-306/215	3 3/8 - 2 15/16	85 - 75
4222907975	INS HEX RED. RTX30-INS-306/212	3 3/8 - 2 3/4	85 - 70
4222907976	INS HEX RED. RTX30-INS-308/306	3 1/2 - 3 3/8	-
4222907977	INS HEX RED. RTX30-INS-308/302	3 1/2 - 3 1/8	-
4222907978	INS HEX RED. RTX30-INS-308/215	3 1/2 - 2 15/16	-
4222907979	INS HEX RED. RTX30-INS-090/085	-	90 - 85
4222907980	INS HEX RED. RTX30-INS-090/080	-	90 - 80
4222907981	INS HEX RED. RTX30-INS-090/075	-	90 - 75
4222907982	INS HEX RED. RTX30-INS-095/090	-	95 - 90
4222907983	INS HEX RED. RTX30-INS-312/306	3 3/4 - 3 3/8	95 - 85
4222907984	INS HEX RED. RTX30-INS-312/302	3 3/4 - 3 1/8	95 - 80
4222907985	INS HEX RED. RTX30-INS-314/312	3 7/8 - 3 3/4	-
4222907986	INS HEX RED. RTX30-INS-314/308	3 7/8 - 3 1/2	-
4222907987	INS HEX RED. RTX30-INS-314/306	3 7/8 - 3 3/8	-
4222907988	INS HEX RED. RTX30-INS-100/095	-	100 - 95
4222907989	INS HEX RED. RTX30-INS-100/090	-	100 - 90
4222907990	INS HEX RED. RTX30-INS-100/085	-	100 - 85
4222907991	INS HEX RED. RTX30-INS-105/100	-	105 - 100
4222907992	INS HEX RED. RTX30-INS-105/095	-	105 - 95
4222907993	INS HEX RED. RTX30-INS-105/090	-	105 - 90
4222907994	INS HEX RED. RTX30-INS-404/314	4 1/4 - 3 7/8	-
4222907995	INS HEX RED. RTX30-INS-404/312	4 1/4 - 3 3/4	-
4222907996	INS HEX RED. RTX30-INS-404/308	4 1/4 - 3 1/2	-
4222907997	INS HEX RED. RTX30-INS-110/105	-	110 - 105
4222907998	INS HEX RED. RTX30-INS-110/100	-	110 - 100
4222907999	INS HEX RED. RTX30-INS-110/095	-	110 - 95
4222908000	INS HEX RED. RTX30-INS-115/110	-	115 - 110
4222908001	INS HEX RED. RTX30-INS-115/105	-	115 - 105
4222908002	INS HEX RED. RTX30-INS-115/100	-	115 - 100
4222908003	INS HEX RED. RTX30-INS-410/404	4 5/8 - 4 1/4	-
4222908004	INS HEX RED. RTX30-INS-410/314	4 5/8 - 3 7/8	-
4222908005	INS HEX RED. RTX30-INS-410/312	4 5/8 - 3 3/4	-
4222908006	INS HEX RED. RTX30-INS-120/115	-	120 - 115
4222908007	INS HEX RED. RTX30-INS-120/110	-	120 - 110
4222908008	INS HEX RED. RTX30-INS-120/105	-	120 - 105
4222908009	INS HEX RED. RTX30-INS-500/410	5 - 4 5/8	-

Insert Hex Reducer ordering numbers

Ordering No.	Assy Description	Size	
		Inch	mm
4222908010	INS HEX RED. RTX30-INS-500/404	5 - 4 1/4	-
4222908011	INS HEX RED. RTX30-INS-500/314	5 - 3 7/8	-
4222908012	INS HEX RED. RTX30-INS-130/120	-	130 - 120
4222908013	INS HEX RED. RTX30-INS-130/115	-	130 - 115
4222908014	INS HEX RED. RTX30-INS-130/110	-	130 - 110
4222908015	INS HEX RED. RTX30-INS-135/130	-	135 - 130
4222908016	INS HEX RED. RTX30-INS-135/120	-	135 - 120
4222908017	INS HEX RED. RTX30-INS-135/115	-	135 - 115
4222908018	INS HEX RED. RTX30-INS-506/500	5 3/8 - 5	-
4222908019	INS HEX RED. RTX30-INS-506/410	5 3/8 - 4 5/8	-
4222908020	INS HEX RED. RTX30-INS-506/404	5 3/8 - 4 1/4	-

RT Advance

Controlled, precise and accurate hydraulic wrench system



Wifi
Remote access system support

4 USB ports (for bar code reader, label printer etc.)
1 VGA
1 LAN
Speaker, Mic
1 RS232 port

Highly effective radiator cooling system for
continuous operation

Class 1 gauge
Pressure sensor with 0.25% full scale
resolution
Proven solenoid valves
Reliable couplers.
Powerpack options (P55 / P150)



Full featured remote control with output
signals for Ok, NOK, low torque, high
torque, untightening

Twin-line hose with couplers
cables for sensor and encoder.
Special high resistant wrap.

Detachable, reversible angle encoder
Sensor controlled auto cycle
Integrated retainer for square drive tools



Atlas Copco RT Advance hydraulic wrench system

For years, Atlas Copco has been known for providing electrical transducerized tightening solutions with technology that keeps you ahead of the game and helps you and your customers to achieve sustainable productive growth.

RT advance is the beginning of our developments towards achieving similar standards with hydraulics.

Features

- Multifunction controller
- HD 10" Colour touch Screen
- 16GB inbuilt memory
- 4 identifiers for traceability
- User friendly interface
- Torque, Angle and time based strategies
- Open protocol / ToolsNet
- VDE / VDI 2862 Part 2 compliant

Software

User friendly software programming enables operator to design parameter sets to be used on different applications and scenarios.

Following strategies arrest most of material, machine and human made errors and provide traceability to improve.

- Torque control and time monitoring
- Torque control and angle monitoring with time
- Angle control and torque monitoring with time

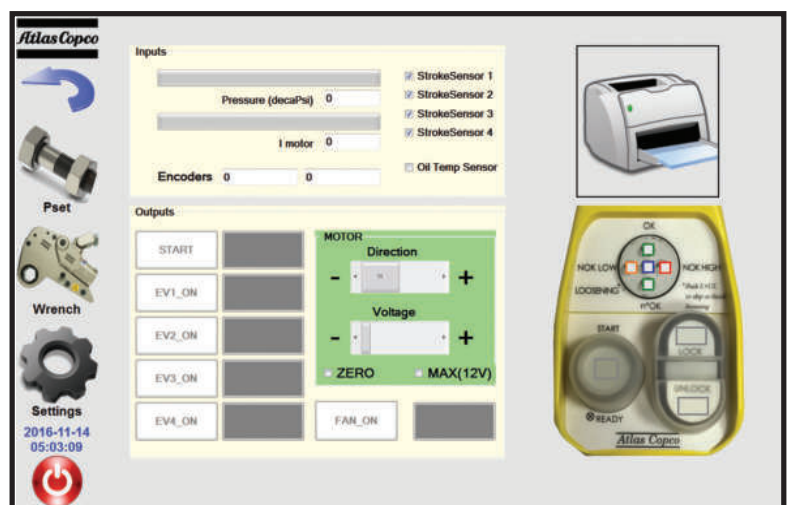
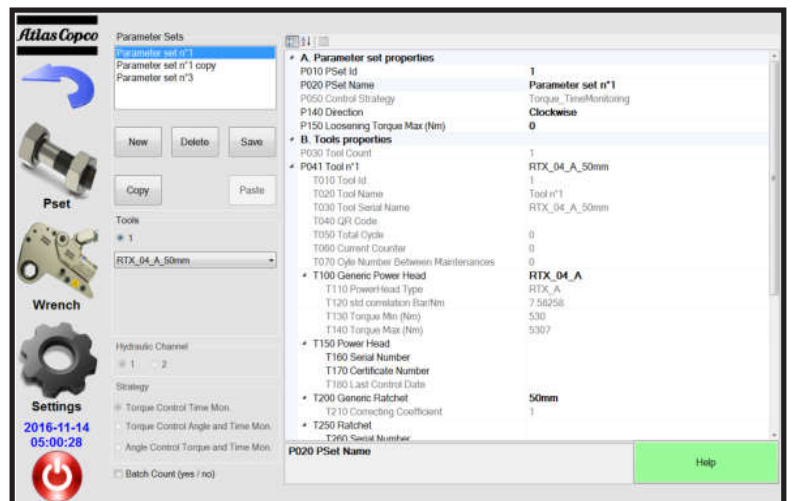
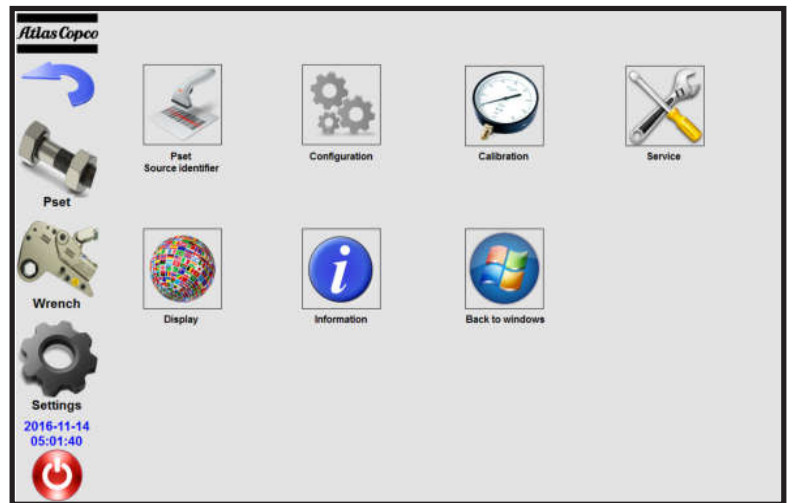

Tool options

RTA tools use the same platform as our standard TF/RT square drive and TFX/RTX direct fit tools but with additional sensors and provisions for reversible encoder. Angle encoder option empowers tool to report even a small deviation in angle (2048 readable positions over 360° rotation) and report errors.



Direct fit (AA)



Square drive (AA)



Direct fit (A)

RTA advance tools are designed to meet industry requirements of traceability and data recording. Please contact local sales for more details.

RTA Product Range	Ft.lb		Nm	
Square Drive Tools	Min	Max	Min	Max
RT1 A (w/o encoder) RT1 AA (with encoder)	195	1390	264	1885
RT3 A (w/o encoder) RT3 AA (with encoder)	453	3230	614	4379
RT5 A (w/o encoder) RT5 AA (with encoder)	783	5590	1061	7579
RT8 A (w/o encoder)	1120	8000	1519	10847
Direct fit tools				
RTX2 power head	257	1710	348	2318
RTX4 power head	578	3855	784	5227
RTX8 power head	1223	8151	1658	11051
Ratchet Links				
RL02 A (w/o encoder) RL04 A (w/o encoder) RL08 A (w/o encoder)	Check for standard range of available ratchets.			
RL02 AA (with encoder) RL04 AA (with encoder)				
Powerpacks (220 / 110 V)				
RTA 150- Opt. 1 (Torque, Time) 4 port RTA 150- Opt. 2 (Torque, Angle, Time) 1 port RTA 150- Opt. 3 (Torque, Angle, Time) 2 port	Powerpacks complete with controller, pressure sensor, DC drive, full frame and protection cover			
Hoses				
Hoses 4,5m for RTA Hoses 10m for RTA Hoses 15m for RTA Hoses 20m for RTA	With cables for stroke sensor, encoder and protective cover			

SP700

A premium powerpack for torque tools



With smart tools becoming more important for all sectors, you need a premium powerpack to carry out the work

The new SP700 Hydraulic Torque Powerpack is equipped with a range of features to increase productivity in your torque processes. Integrating this powerpack into your operations, you can increase tightening speeds by upto 30%.

Investing in great tools can take you a long way. Choosing an intelligent hydraulic powerpack will take you even further. A quicker process and a safer operation makes the SP-700 a smarter choice. Not to mention the worry free operation and ergonomic benefits.

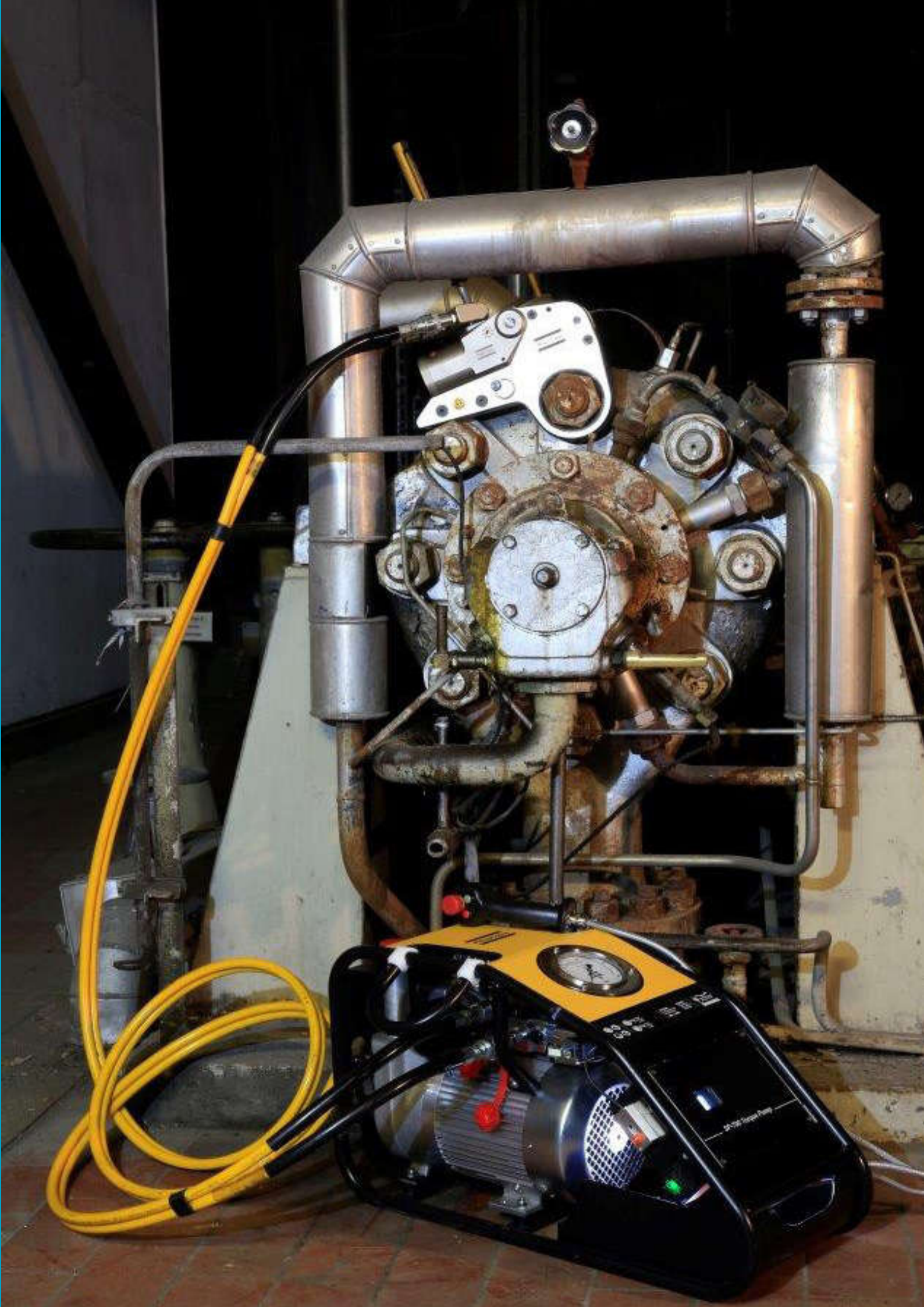

Premium Powerpack



SP700

- Three stage
- Effective oil cooling system
- High strength steel frame
- Oil filter for enhanced life
- Class 1 gauge (+/- 1% full scale)
- Auto shutoff after 1 minute idling
- High temperature protection

30%
Increase in
tightening speed
meaning less
process time

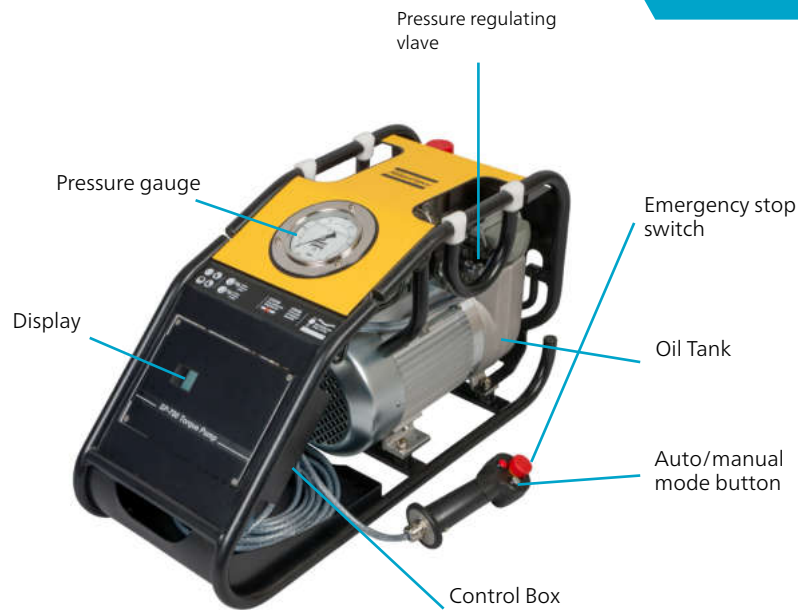

Model	Current Supply			Oil flow 120 bar l/m	Oil flow max pressure l/m	Usable oil capacity		Max Pressure bar	Weight		Height		Width		Length		Ordering No.
	Voltage	Frequency	Current			l	Gal		kg	Lb	mm	in	mm	in	mm	in	
SP-700-230	230 V	50 Hz	10 A	6.89	1.10	1.7	0.45	700	33	72.7	370	14.6	278	10.9	680	26.8	8434 2040 47
SP-700-115	115 V	60 Hz	22 A	6.33	0.86	1.7	0.45	700	33	72.7	370	14.6	278	10.9	680	26.8	8434 2040 48

Accessories	Order number
4 port manifold kit	8434 2040 50
Maximizer 22 Oil	8434 2040 49





Electric torque wrench powerpacks

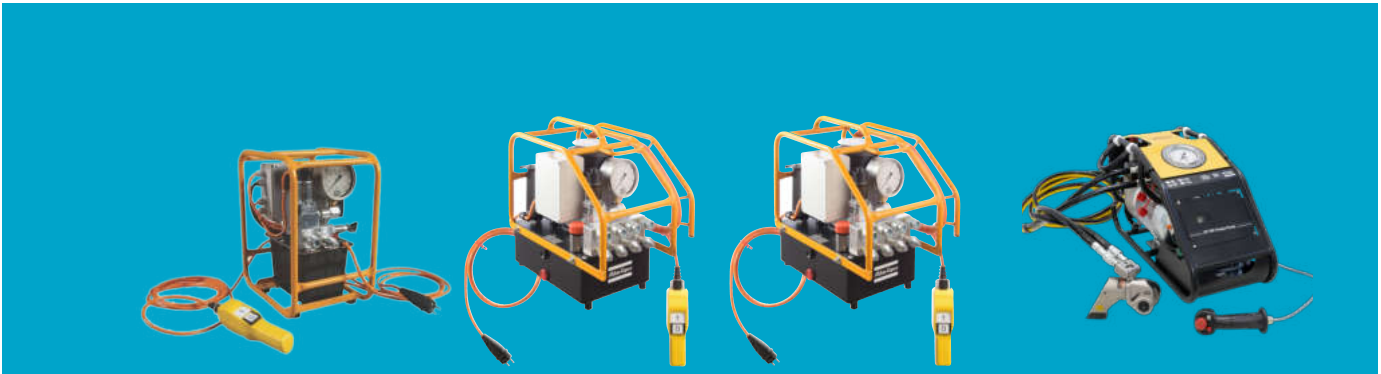

Panther 025 Panther 55 Panther 150 SP-700

	1 Port	4 Ports	4 Ports	4 Ports	1 Port	 1 Port
Twin	8434 2040 33 (115V) 8434 2059 54 (230V)	8434 2040 35 (115V) 8434 2040 37 (230V)	8434 2040 39 (115V)	8434 2040 41 (230V)	8434 2040 48 (115V)	8434 2040 47 (230V) 50Hz 8434 2040 48 (230V) 60Hz

Ordering Numbers	1 Port	1 Port	1 Port	1 Port	1 Port	1 Port
Co-Ax	8434 2430 29 (115V) 8434 2430 30 (230V)	8434 2420 88 (230V) 8434 2420 90 (115V)	8434 2420 94(115V)	8434 2420 92 (230V)	8434 2420 99 (115V) 60Hz	8434 2420 98 (230V) 50Hz 8434 2421 00 (230V) 60Hz
		4 Ports 8434 2420 89 (230V) 8434 2420 91 (115V)	4 Ports 8434 2420 91 (115V)	4 Ports 8434 2420 89 (230V)		

Dimensions (LxWxH)	inches	14.1 x 12.2 x 17.3	17.3 x 12.6 x 16.5	17.3 x 13 x 17.3	17.3 x 13 x 17.3	26.8 x 10.9 x 14.6	26.8 x 10.9 x 14.6
	mm	360 x 310 x 440	460 x 320 x 420	440 x 330 x 440	440 x 330 x 440	680 x 278 x 370	680 x 278 x 370
Weight (w/o / with oil)	lb	42.6 / 46.6	61.6 / 70.4	64.9 / 73.7	64.9 / 73.7	69/72.7	69 / 72.7
	kg	19.4 / 21.1	28 / 32	29.5 / 33.5	29.5 / 33.5	35.6 / 37.5	35.6 / 37.5
Oil Capacity	Gallons	0.45	1.05	1.05	1.05	0.45	0.45
	Liters	1.7	4.0	4.0	4.0	1.7	1.7
Intercooler System		No	Yes	Yes	Yes	Yes	Yes
Auto Cycle		No	No	No	No	Yes	Yes
Oil Flow@ 1250psi/86bar	cu.in	195 cu. in/min	391 cu. in/min	463 cu. in/min	517.6 cu. in/min		
	l/min	3.2 l/min	6.4 l/min	7.6 l/min	8.5 l/min		
Oil Flow@ 1740psi/120bar						386 cu.in/min	420 cu.in/min
						6.33 l/min	6.89 l/min
Oil Flow@ 3600psi/250bar		54 cu. in/min	110 cu. in/min	183 cu. in/min	207.0 cu. in/min		
		0.9 l/min	1.8 l/min	3.0 l/min	4.4 l/min		

Recommended Tools	RT0.5	•	•			
	RT1/TF01	•	•			•
	RT3/TF03	•	•			•
	RT5/TF05		•			•
	RT8/TF08		•		•	•
	RT10/TF10		•		•	•
	RT20		•		•	•
	RT25		•		•	•
	RT50		•		•	•
	TFX02	•	•		•	•
	TFX04		•		•	•
	TFX08		•		•	•
	TFX14		•		•	•
	TFX18		•		•	•
	TFX30		•		•	•

* 4-port manifold is available as an optional accessory. See the powerpack accessory page for order.

91 Hoses and oil not included with the powerpack. Be sure to order corresponding amount of oil for your powerpack and select hose length for your application.

Air torque wrench powerpacks



		Panther A110	Panther A380
Ordering Numbers	Twin	Full Frame 8434 2040 17	4 Ports 8434 2040 22 (ATEX) 8434 2040 23
	Co-Ax	On Request	1 Port 8434 2420 96 4 Ports 8434 2420 97
Dimensions (Lx-WxH)	inches	15.7 x 13 x 18.5	19.6 x 10.6 x 15.7
	mm	400 x 330 x 470	500 x 270 x 400
Weight (w/o / with oil)	lb	47.3 / 55.2	60.9 / 68.8
	kg	21.5 / 25.1	27.7 / 31.3
Oil Capacity	Gallons	0.95	0.95
	Liters	3.6	3.6
Oil Flow@ 675bar	cu.in	275 cu.in/min	456.75 cu. in/min
	l/min	4.5 l/min	7.5 l/min
Oil Flow@ 75-220bar		67 cu in./min	152 cu. in/min
		1.1 l/min	2.5 l/min
Oil Flow@ Up to 700bar		24 cu. in/min	54.8 cu.in/min
		0.4 l/min	0.9 l/min
Recommended Tools	RT0.5	•	•
	RT1/TF01	•	•
	RT3/TF03	•	•
	RT5/TF05		•
	RT8/TF08		•
	RT10/TF10		•
	RT20/TF20		•
	RT25/TF25		•
	RT50/TF50		•
	TFX02	•	•
	TFX04		•
	TFX08		•
	TFX14		•
	TFX18		•
TFX30		•	

* 4-port manifold is available as an optional accessory. See the powerpack accessory page for order.

Maintenance kits are available for every powerpack model. Consult your local Atlas Copco bolting representative

Accessories for hydraulic torque wrench powerpacks



Twin-line hoses

Model	Length (M)	Length ft)	Ordering No.
90172	4.5M	15 ft	8434 2050 08
090172-7	7M	22.9 ft	8434 2123 95
090172-10	10M	32 ft	8434 2123 74
090172-15	15M	49.2 ft	8434 2050 10
090172-20	20M	65.6 ft	8434 2123 83
090172-30	30M	98.4 ft	8434 2123 86
90172	4.5M	15 ft	8434 2050 09



Co-Axial hoses & accessories

Model	Length (M)	Length ft)	Ordering No.
Co-Axial Hose	4.5M	15 ft	8434242080
Co-Axial Hose	10M	32 ft	8434242151
Co-Ax Accessory	Co-Axial 90Deg Elbow		4222905306



Hydraulic oil

Model	Description	Ordering No.
Tellus 46	5L / 1.32G Container	8434204045
Maximizer 15	5L / 1.32G Container	8434204051
Maximizer 22	5L / 1.32G Container	8434204049
Maximizer 32	5L / 1.32G Container	8434220002
Maximizer 46	5L / 1.32G Container	8434204045
Maximizer 68	5L / 1.32G Container	8434220001



Gauges

Model	Description	Ordering No.
090233-2	Gauge 70Mpa Back Mounted	8434 2124 07
090233-1	Gauge 700bar-10kpsi	8434 2051 59



Manifolds

Model	Description	Ordering No.
1-port	Co-Axial Panther Manifold Block	8434241130
4-port	Co-Axial Panther Manifold Block	8434241131
1-port	Co-Axial Retrofit Kit for SP-700	4222908591
1-port	Co-Axial Retrofit Adapter	4222905305

Couplers and fittings



Ordering No.	Description	Design/Shape	Where Used	Alternate Description
8434 2050 06	1/8" Coupler Female		RT-0.5, RT-01, TF-01, TFX/RTX-02	COUPLING, FEMALE SCREW-ON X 1/8"NPT (M)
8434 2123 41	1/4" Female Coupler		RT-03, RT-05, RT08, RT-10,RT-20, RT-25, RT-50, TF-03, TF-05, TF08, TF-10, TFX/RTX-04,TFX/RTX-08,TFX/RTX-14,TFX/RTX-18, TFX/RTX-30, PUMPS, HOSES.	COUPLING, FEMALE SCREW-ON X 1/4"NPT (M)
8434 2123 44	3/8" Female Coupler		RT-03, RT-05, RT08, RT-10,RT-20, RT-25, RT-50, TF-03, TF-05, TF08, TF-10, TFX/RTX-04,TFX/RTX-08,TFX/RTX-14,TFX/RTX-18, TFX/RTX-30, Pumps & Hoses	COUPLING, FEMALE SCREW-ON X 3/8"NPT (M)
8434 2123 65	1/8" Male Coupler		"RT-0.5, RT-01, TF-01, TFX/RTX-02"	COUPLING, MALE SCREW-ON X 1/8"NPT (M)
8434 2131 36	QCCOUPERS Quick Connect Coupler set		Can be used on all wrenches/pumps/hoses as an alternative to standard screw-on-couplings. Adaptors are also required (1/4"NPT or 1/8"NPT as appropriate)	COUPLER SET, QUICK CONNECT MALE & FEMALE
8434 2050 00	Nipple Male-Male 1/4IN-x1/4IN		Used with quick coupler set 8438 2131 36 & can be used with 8434 2123 38 as an alternative to 8434 2123 65	ADAPTOR, 1/4 NPT (M) X 1/4 NPT (M)
8434 2050 02	Nipple Male 1/4INx-1/8IN		Used with quick coupler set 8438 2131 36 & can be used with 8434 2123 38 as an alternative to 8434 2123 65	ADAPTOR, 1/4 NPT (M) X 1/8 NPT (M)
8434 2050 04	Nipple NPT 1/4INx1/4IN		Used to connect in-line gauges & accessories	T-PIECE, 1/4 NPT (M) X 1/4 NPT (M) X 1/4 NPT (F)
8434 2123 38	1/4" Male Female Nipple		Used on pumps and hoses with 8434 2050 00. Can be used as alternative to 8434 2123 68 & 8434 2123 65 when used with appropriate adaptor	COUPLER, MALE SCREW-ON x 1/4 NPT (F)
8434 2123 68	M 1/4" Male Nipple		RT-03, RT-05, RT08, RT-10,RT-20, RT-25, RT-50, TF-03, TF-05, TF08, TF-10, TFX/RTX-04,TFX/RTX-08,TFX/RTX-14,TFX/RTX-18, TFX/RTX-30, Pumps & Hoses.	COUPLING, MALE SCREW-ON X 1/4"NPT (M)
4222901357	Coupling, Co-axial		Used on Pump Manifolds, supplied with O-rings	COUPLING, FEMALE CO-AXIAL x M30x1.5(M)
4222901403	Nipple, Co-axial		Used on Wrenches: TF &TFX Wrench types, Swivel Manifolds, supplied with O-rings	NIPPLE, MALE CO-AXIAL x M30x1.5(M)
4222905355	Hose Coupling, Co-axial		Used on Co-axial Hoses adapts from twin hose to co-axial coupling, supplied with threaded adaptors	HOSE COUPLING, FEMALE CO-AXIAL x G1/4 (M) x M14x1.5(M)
4222905356	Hose Nipple, Co-axial		Used on Co-axial Hoses adapts from twin hose to co-axial nipple, supplied with threaded adaptors	HOSE NIPPLE, MALE CO-AXIAL x G1/4 (M) x M14x1.5(M)

Bolt Tensioning





STS

Smart Tensioning System



Scan me to view the webpage!

Atlas Copco's Smart Tensioning System, puts the bolt tensioning process in your hands

Bolt tensioning can be one of the most complex processes when tightening a bolt, however Atlas Copco have taken that pain away. The **STS - Smart Tensioning System** gives you full control of the bolt tensioning process, giving you the ability to control the whole process from a hand controller.

Receive critical bolting data at the joint, and ensure that each bolt has been tightened correctly. Also you have the ability to store and send data to achieve full transparency.





STS tool features

The Smart Tensioning System is complete with three components; **STT** (Smart Tentec Tensioner), **PFHC** (Power Focus Hand Controller) and the **SP2000** powerpack. Combined they give you the most powerful tensioning solution on the market.

STT the power of the tensioning process



Status LEDs for P-T-A: See pressure torque and angle status directly on the tensioner, as a mirror image of what is shown on the hand controller.

Integrated Sensors: Pressure Torque and angle sensors integrated inside the tensioner for quick and accurate tightening. Internal memory with tool identification

Max pressure 2000 bar: Fitting on cramped wall clearances and delivers high loads.

Fail safe mechanism: With rolled threads and design to fail safe.

Certified lifting point: For safety, so you can move the tool with peace of mind.

Service and incident notification: Alarms to prompt actions on specific events.

PFHC the brains of the operation



- One device to operate the powerpack, scan and guide.
- Built-in barcode scanner.
- Output data through USB or USB-C drives.
- HTML connectivity to create tightening programs.
- Easy configuration for pressure, torque and angle.
- Multistage functionality.
- Bolt tightening status visualization
- Magnetic back for safe placing.
- ToolsNet8 compatibility to store and analyze data.
- Open protocol, so tool data can be shared.

STS ordering numbers

Tensioners

Description	Tensioner stand alone Ordering No.	Tensioner Kit complete (inc Tool+ Frame+Box) Ordering No.
STT-M36 PTA Tensioner	8434221016	8434221000
STT-M42 PTA Tensioner	8434221019	8434221001
STT-M48 PTA Tensioner	8434221022	8434221002
STT-M56 PTA Tensioner	8434221025	8434221003
STT-M64 PTA Tensioner	8434221028	8434221004
STT-M72 PTA Tensioner	8434221031	8434221005



Powerpacks

Ordering No.	Description
8434221006	SP2000 - 400V Powerpack
8434221042	SP2000 - 230V Powerpack
8434221043	SP2000 - 230V Powerpack



System Kit

Ordering No.	Description
8434221010	Smart System Kit
	STS system cable (6m)
	BCV BL-30-10 (Puller rundown tool)
	BCV Battery 36 V
	Battery charger
	CWR -85 (Torque wrench)
	3/8" reversible head
	BCV disengage key
	Transportation Box



Optional Accessories - Suspension Frame

Ordering No.	Description
8434221015	STT-M36 Frame kit
8434221018	STT-M42 Frame kit
8434221021	STT-M48 Frame kit
8434221024	STT-M56 Frame kit
8434221027	STT-M64 Frame kit
8434221030	STT-M72 Frame kit
8434221033	STT-M36 (F) Frame kit - foundation
8434221036	STT-M36 (F) Frame kit - foundation

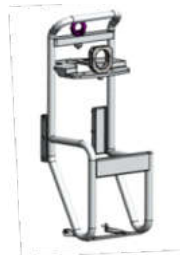

Optional Accessories - Transportation Box

Ordering No.	Description
8434221014	STT-M36 transportation box
8434221017	STT-M42 transportation box
8434221020	STT-M48 transportation box
8434221023	STT-M56 transportation box
8434221026	STT-M64 transportation box
8434221029	STT-M72 transportation box
8434221032	STT-M36 (F) transportation box
8434221035	STT-M42 (F) box
8334221009	Transportation box - System kit



CTST

Topside hydraulic bolt tensioner

Threaded insert

Contains a matching female thread to the bolt being tensioned.

Reliable seals

Proven seal technology ensures many 1000's of tool pressure cycles.

Piston stroke

15mm piston/ram stroke capability on models CTST 02 - CTST 06.

Versatile

Detachable and Interchangeable bridge component.



Topside tensioners for several applications in multiple industries.

Atlas Copco CTST range of topside bolt tensioning tools comprises 6 base tools covering bolt sizes from 3/4" to 4" (M20 to M100). The tools are designed to fit on to most ANSI B16.5, ANSI B16.47 Series 1, MSS-SP44, API-6A and API-17D flanges. Each base tool can be converted for use with different bolt sizes using a conversion kit.



Hydraulic connections
User configurable quick release connections.

Nut Rotating Socket (NRS)
Fits around the bolted joint nut to allow for easy rotation.



CTST bolt tensioners ordering numbers

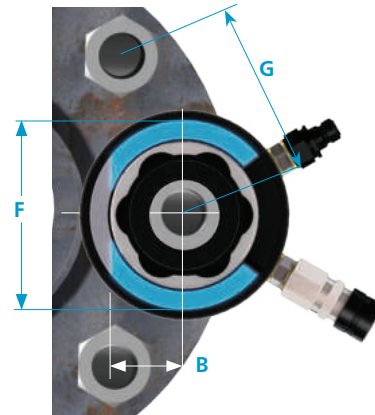
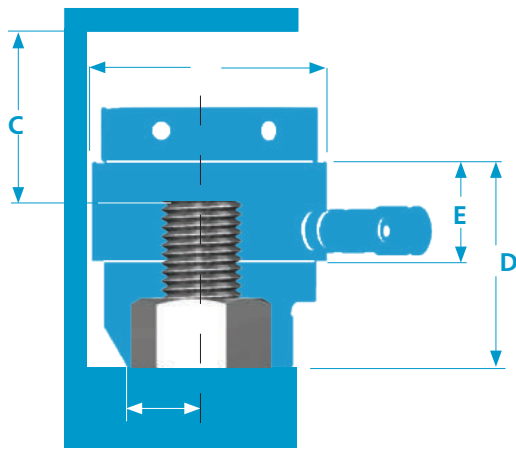

Tool	Part No. Imperial	Thread Size		Part no. Metric	Bolt Load Kn	Stroke mm	Weight kg	A	B	C	D	E	F	G		
		Inch	mm												mm	
No 1	8434220070	3/4"-10UNC	M20x2.5	8434220071	227	10	2.0	73.50	21.0	67.00	71.0	45	62	49.5		
	8434220072	7/8"-9UNC	M22x2.5	8434220073											63	53
	8434220074	1"-8UN	M24x3	8434220075											69	58.5
	8434220076	1 1/8"-8UN	M27x3	8434220077											74	63.5
No 2	8434220079	1 1/8"-8UN	M27x3	8434220080	443	15	4.8	102	27.0	85.50	92.0	54	82	67.5		
			M30x3.5	8434220082											85	69
	8434220081	1 1/4"-8UN	M33x3.5	8434220083											85	72
	8434220084	1 3/8"-8UN	M36x4	8434220085											91	78
	8834220086	1 1/2"-8UN	M39x4	8434220087											90	80
No 3	8834220089	1 1/2"-8UN	M39x4	8434220094	810	15	9.5	133	36.5	98.00	109.0	56	97	83.5		
	8434220090	1 5/8"-8UN	M42x4.5	8434220095											110	92.5
	8434220091	1 3/4"-8UN	M45x4.5	8434220096											115	98
	8434220092	1 7/8"-8UN	M48x5	8434220097											116	101
	8434220093	2"-8UN	M52x5	8434220098											120	106
No 4	8434220100	1 7/8"-8UN	M48x5	8434220103	1273	15	16.1	163	43.5	106.00	118.0	57	130	108		
	8434220101	2"-8UN	M52x5	843422105											124	108
	8434220104	2 1/4"-8UN	M56x5.5	843422106											134	118.5
			M60x5.5	843422107											150	127
	8434220102	2 1/2"-8UN	M64x6	843422108	147	130.5										
No 5	8434220110	2 1/2"-8UN	M64x6	8434220113	1829	15	22.7	193	64.0	107.50	133.0	60	147	130.5		
			M68x6	8434220114											160	138
	84342200111	2 3/4"-8UN	M72x6	8434220115											161	143
	8434220112	3"-8UN	M76x6	8434220116											170	153
	8434220126	3"-8UN	M76x6	8434220130	170	153										
			M80X6	8434220131	178	155.5										
No 6	8434220125	3 1/4"-8UN	M85X6	8434220132	2644	15	38.1	233	78.0	114.00	154.0	64	182	165.5		
	8434220127	3 1/2"-8UN	M90X6	8434220133											191	174.5
	8434220128	3 3/4"-8UN	M95X6	8434220134											210	189.5
	8434220129	4"-8UN	M100X6	8434220135											220	200

CTST conversion kit ordering numbers

Conversion kits offer a very economical way to expand your inventory of bolt tensioning tools. Kits are available to convert a Atlas Copco CTST tensioner to suit an alternative bolt size within its size range.

Conversion Kits consist of three items:

- 1 Thread insert
- 2 Bridge piece
- 3 Nut rotating socket

You combine the conversion kit with:

- 4 Load cell



Tool No.	Load Cell Ordering No.	Metric description	Metric Ordering No.	Imperial description	Imperial Ordering No.
No.1	8434220069	M20x2.5	4222260002	3/4"-10UNC	4222260001
	8434220069	M22x2.5	4222260004	7/8"-9UNC	4222260003
	8434220069	M24x3	4222260006	1"-8UN	4222260005
	8434220069	M27x3	4222260008	1.1/8"-8UN	4222260007
No.2	8434220078	M27x3	4222260010	1.1/8"-8UN	4222260012
	8434220078	M30x3.5	4222260011		
	8434220078	M33x3.5	4222260013	1.1/4"-8UN	4222260009
	8434220078	M36x4	4222260015	1.3/8"-8UN	4222260014
	8434220078	M39x4	4222260017	1.1/2"-8UN	4222260016
No.3	8434220088	M39x4	4222260019	1.1/2"-8UN	4222260018
	8434220088	M42x4.5	4222260021	1.5/8"-8UN	4222260020
	8434220088	M45x4.5	4222260023	1.3/4"-8UN	4222260022
	8434220088	M48x5	4222260025	1.7/8"-8UN	4222260024
	8434220088	M52x5	4222260027	2"-8UN	4222260026
No.4	8434220099	M48x5	4222260029	1.7/8"-8UN	4222260028
	8434220099	M52x5	4222260031	2"-8UN	4222260030
	8434220099	M56x5.5	4222260033	2.1/4"-8UN	4222260032
	8434220099	M60x5.5	4222260034		
	8434220099	M64x6	4222260036	2.1/2"-8UN	4222260035
No.5	8434220109	M64x6	8434220118	2.1/2"-8UN	8434220117
	8434220109	M68x6	8434220119		
	8434220109	M72x6	8434220121	2.3/4"-8UN	8434220120
	8434220109	M76x6	8434220123	3"-8UN	8434220122
No.6	8434220124	M76x6	4222260038	3"-8UN	4222260037
	8434220124	M80X6	4222260039		
	8434220124	M85X6	4222260041	3.1/4"-8UN	4222260040
	8434220124	M90X6	4222260043	3.1/2"-8UN	4222260042
	8434220124	M95X6	4222260045	3.3/4"-8UN	4222260044
	8434220124	M100X6	4222260047	4"-8UN	4222260046

You can order a complete tensioner for the stud size using the table above, or you can order load cells and conversion kits as needed. Many different configurations are available for our CTST bolt tensioners.

Airbac

Patented piston return technology

Reduced diameter thread insert provides weight saving

One way air valve for rapid re-charging

One piece end cap and valve protection brackets



Interchangeable with CTST loads proof prints and HPA.

Outside diameter same as CTST model ensuring compatibility with ASME, ANSI and API flanges

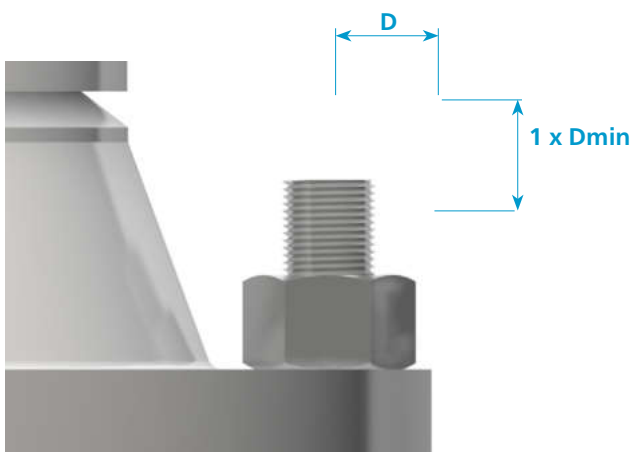

The patented Airbac range of Atlas Copco topside bolt tensioning tools consist of 6 base tools covering bolt sizes from 3/4" to 4" (M20 to M100). The tools are designed to fit on to most ANSI B16.5, ANSI B16.47 Series 1, MSS-SP44, API-6A and API-17D flanges.

Bolt protrusion

The patented Airbac Series tensioners need a minimum of 1 x bolt diameter protruding above the hexagon or round nut.

Why do we need air-assisted tensioners?

We had customers using spring assisted return tensioners where they particularly complained about springs losing their tension, in due course of time and needed some last bit of retracting to be manually done. This keeps increasing as time passes and leads to more effort as with manual piston return type tensioners. We listened to these customers and developed the Airbac patented technology.

Benefits of Airbac

- Hands free complete piston retract
- Upto 3.5 times faster retract than spring return
- Every charge gives same retract force as new
- No break in work due to vulnerable spring failures
- Highly corrosion resistant electroless nickel plating.
- Just 6 load cells cover ¾" to 4" bolt sizes.
- Fits all standard O&G flange applications.

Did you know?

Conventional tensioners need manual-retract of the piston which is achieved by rotation of inserts over bolts against high friction due to oil and seals working inside the tensioner. Potentially this can even lead to, or add to the reasons of having Lateral epicondylitis, also commonly referred to as tennis elbow, which is a cumulative trauma disorder (CTD). It's fast, safe and hands-free tensioning recedes fatigue, risk of accidents and long term health concerns. There is nothing before safety and even the small things matter a lot.

Please use this as reference for measurements on the next page

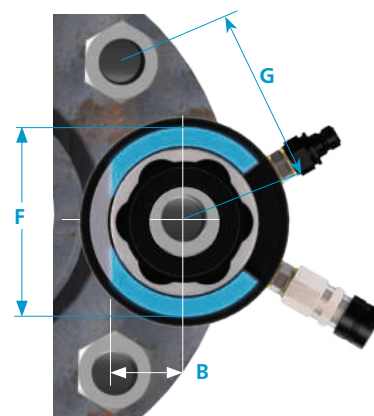
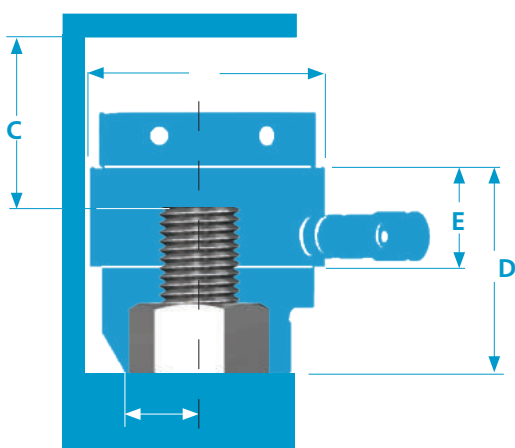

Airbac ordering numbers Working Pressure = 1500bar

Tool Identification	Thread Size	Part Number	Dimensions						
			A	B	C	D	E	F	G
AB-01 (Airbac technology not included)	3/4"	8434 2204 31	73.50	21	75	79	45	62	49.5
	M20 x 2.5	8434 2204 32		21	74	63		49.5	
	7/8"	8434 2204 33		24	72	79		63	53
	M22 x 2.5	8434 2204 34		24	72	79		63	53
	1"	8434 2204 35		24	75.75	86		69	58.5
	M24 x 3	8434 2204 36		24	77	86		69	58.5
	1 1/8"	8434 2204 37		27	73.5	87		74	63.5
	M27 x 3	8434 2204 38		27	75	87		74	63.5
AB-02 (Airbac technology not included)	1 1/8"	8434 2204 40	102	27	97.5	104	66	82	67.5
	M27 x 3	8434 2204 41		27	99	104		82	67.5
	M30 x 3.5	8434 2204 42		32	97	105		85	69
	1 1/4"	8434 2204 43		31	97.5	107		85	72
	M33 x 3.5	8434 2204 44		31	96	107		85	72
	1 3/8"	8434 2204 45		34	97.25	110		91	78
	M36 x 4	8434 2204 46		34	96	110		91	78
	1 1/2"	8434 2204 47		36.5	96	112		90	80
AB-03	M39 x 4	8434 2204 48	133	36.5	95	112	100	90	80
	M36 x 4	8434 2204 50		36.5	130.5	153		97	83.5
	1 1/2"	8434 2204 51		36.5	128.5	153		97	83.5
	M39 x 4	8434 2204 52		36.5	127.5	153		97	83.5
	1 5/8"	8434 2204 53		37.5	123.25	151		110	92.5
	M42 x 4.5	8434 2204 54		37.5	122.5	151		110	92.5
	1 3/4"	8434 2204 55		40.5	129.25	160		115	98
	M45 x 4.5	8434 2204 56		40.5	128.5	160		115	98
	1 7/8"	8434 2204 57		42.5	126	160		116	101
	M48 x 5	8434 2204 58		42.5	125.5	160		116	101
AB-04	2"	8434 2204 59	163	50	123.75	161	100	120	106
	M52 x 5	8434 2204 60		50	122.5	161		120	106
	M42 x 4.5	8434 2204 62		43.5	134.25	161		120	106
	1 7/8"	8434 2204 63		43.5	128.75	161		130	108
	M48 x 5	8434 2204 64		43.5	128.25	161		130	108
	2"	8434 2204 65		46	124.5	160		130	108
	M52 x 5	8434 2204 66		46	123.25	160		124	108
	2 1/4"	8434 2204 67		55	124.25	166		124	108
	M56 x 5.5	8434 2204 68		55	125.25	166		134	118.5
	M60 x 5.5	8434 2204 69		54	143.75	188.5		134	118.5
AB-05	2 1/2"	8434 2204 70	193	58	124.75	173	111.25	150	127
	M64 x 6	8434 2204 71		58	124.25	173		147	130.5
	2 1/2"	8434 2204 73		64	138.25	184.25		147	130.5
	M64 x 6	8434 2204 74		64	137.75	184.25		147	130.5
	M68 x 6	8434 2204 75		80	141.75	192.25		160	138
	2 3/4"	8434 2204 76		72	146	198.25		161	143
	M72 x 6	8434 2204 77		72	143.75	198.25		161	143
	3"	8434 2204 78		77	138.75	197.25		170	153
AB-06	M76 x 6	8434 2204 79	233	77	138.75	197.25	111.25	170	153
	3"	8434 2204 81		77	141.75	200.25		170	153
	M76 x 6	8434 2204 82		77	141.75	200.25		170	153
	M80 x 6	8434 2204 83		78	138.75	201.25		178	155.5
	3 1/4"	8434 2204 84		78	136.25	201.25		182	165.5
	M85 x 6	8434 2204 85		78	133.75	201.25		182	165.5
	3 1/2"	8434 2204 86		86	136	207.25		191	174.5
	M90 x 6	8434 2204 87		86	134.75	207.25		191	174.5
	3 3/4"	8434 2204 88		99	137.5	215.25		210	189.5
	M95 x 6	8434 2204 89		99	137.75	215.25		210	189.5
AB-06	4"	8434 2204 90	233	105	137.25	221.25	111.25	220	200
	M100 x 6	8434 2204 91		105	138.75	221.25		220	200

Designs and specifications are subject to change without notice or obligation. Read all safety instructions in the manual before usage. AB-01 and AB-02 are manual retract tensioners.

Tool Identification	Thread Size	Part No	Tool Load		Hydraulic Pressure Area		Stroke		Total Tool Weight		Load Cell Weight Only	
			kN	Ton	mm2	In2	mm	In	kg	lbs	kg	lbs
AB-01 (Airbac technology not included)	3/4"	4222 2600 50							2.71	5.96		
	M20 x 2.5	4222 2600 51							2.71	5.96		
	7/8"	4222 2600 52							2.61	5.74		
	M22 x 2.5	4222 2600 53	227.812	22.864	1518.746	2.354	10	0.394	2.62	5.76	1.64	3.61
	1"	4222 2600 54							2.71	5.96		
	M24 x 3	4222 2600 55							2.76	6.07		
	1 1/8"	4222 2600 56							2.73	6.01		
AB-02 (Airbac technology not included)	M27 x 3	4222 2600 57							2.81	6.18		
	1 1/8"	4222 2600 58							5.58	12.28		
	M27 x 3	4222 2600 59							5.64	12.41		
	M30 x 3.5	4222 2600 60							5.68	12.50		
	1 1/4"	4222 2600 61							5.5	12.10		
	M33 x 3.5	4222 2600 62	443.060	44.466	2953.734	4.578	10	0.394	5.49	12.08	3.02	6.64
	1 3/8"	4222 2600 63							5.56	12.23		
AB-03	M36 x 4	4222 2600 64							5.57	12.25		
	1 1/2"	4222 2600 65							5.76	12.67		
	M39 x 4	4222 2600 66							5.71	12.56		
	M36 x 4	4222 2600 67							11.83	26.03		
	1 1/2"	4222 2600 68							11.7	25.74		
	M39 x 4	4222 2600 69							11.73	25.81		
	1 5/8"	4222 2600 70							11.4	25.08		
AB-04	M42 x 4.5	4222 2600 71							11.55	25.41		
	1 3/4"	4222 2600 72	810.849	81.378	5405.665	8.379	10	0.394	11.68	25.70	6.53	14.37
	M45 x 4.5	4222 2600 73							11.74	25.83		
	1 7/8"	4222 2600 74							11.54	25.39		
	M48 x 5	4222 2600 75							11.63	25.59		
	2"	4222 2600 76							11.18	24.60		
	M52 x 5	4222 2600 77							11.2	24.64		
AB-05	M42 x 4.5	4222 2600 78							18.33	40.33		
	1 7/8"	4222 2600 79							17.87	39.31		
	M48 x 5	4222 2600 80							17.97	39.53		
	2"	4222 2600 81							17.53	38.57		
	M52 x 5	4222 2600 82	1273.489	127.809	8489.933	13.159	10	0.394	17.57	38.65	9.52	20.94
	2 1/4"	4222 2600 83							17.91	39.40		
	M56 x 5.5	4222 2600 84							18.32	40.30		
AB-06	M60 x 5.5	4222 2600 85							20.56	45.23		
	2 1/2"	4222 2600 86							17.4	38.28		
	M64 x 6	4222 2600 87							17.74	39.03		
	2 1/2"	4222 2600 88							26.76	58.87		
	M64 x 6	4222 2600 89							27.12	59.66		
	M68 x 6	4222 2600 90							27.82	61.20		
	2 3/4"	4222 2600 91	1829.474	183.608	12196.497	18.905	10	0.394	28.85	63.47	14.59	32.10
AB-07	M72 x 6	4222 2600 92							29.1	64.02		
	3"	4222 2600 93							26.76	58.87		
	M76 x 6	4222 2600 94							27.57	60.65		
	3"	4222 2600 95							41.22	90.68		
	M76 x 6	4222 2600 96							41.99	92.38		
	M80 x 6	4222 2600 97							41.31	90.88		
	3 1/4"	4222 2600 98							41.19	90.62		
AB-08	M85 x 6	4222 2600 99							41.72	91.78		
	3 1/2"	4222 2601 00	2644.126	265.368	17627.506	27.323	10	0.394	40.32	88.70	20.11	44.24
	M90 x 6	4222 2601 01							40.97	90.13		
	3 3/4"	4222 2601 02							40.58	89.28		
	M95 x 6	4222 2601 03							41.77	91.89		
	4"	4222 2601 04							40.7	89.54		
	M100 x 6	4222 2601 05							41.61	91.54		

Compact 8

Subsea hydraulic bolt tensioner

Release Button
For rapid speed of use.

Stainless Steel
Durable and low maintenance.

Hydraulic Connections
User configurable connections.



The Compact 8 series is designed for subsea applications, and have been used 800 metres below sea level

The Subsea COMPACT-8 range of bolt tensioning tools brings a new generation of bolting solutions. Comprising just 8 bolt tensioning models, the COMPACT-8 series is capable of tensioning most standard flanges and compact flanges.

The COMPACT-8 series is made from high strength stainless steel which greatly reduces maintenance work to a minimum after subsea use.



Split reaction Nut
The split nut delivers speed to the subsea tensioning process. With the ability to quickly attach & detach the component underwater, you can sufficiently tension bolts without a threaded insert.



Grip Surface
For easy diver handling.

Rear profile
Machined for versatility.

Machined flats
To clear the adjacent nuts.

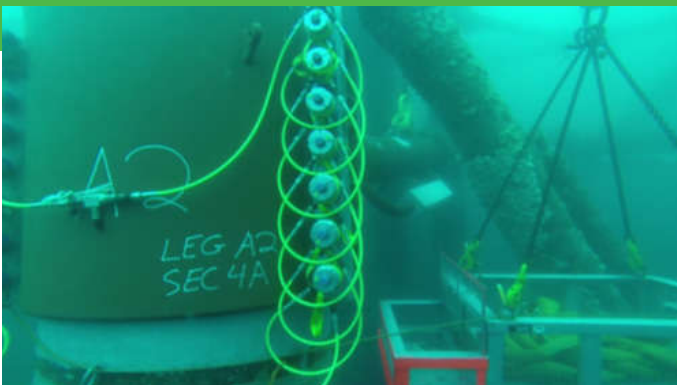

Compact 8 technical data

Model	Ordering No.	Bolt Dia		Tool Dia	Side Dia	Tool Height	Radial Dim'n	Max Initial Bolt Load	Hyd Area mm ²	Ram Stroke	Extra Stud Length	Headroom Dimension	AF	Radial Dim'n	Dim'n
		D	Thread Pitch	A	F	B	C				G	E		H	J
		Inch		mm	mm	mm	mm	kN	mm	mm	mm	mm	mm	mm	mm
C8-00	8434220372	0.75	UNC	66.0	66.0	123	20	190.21	1268.420	20	113.5	214.5	50.2	31.6	97.00
	8434220373	0.875	UNC	66.0	66.0	123	20	190.21	1268.420	20	110.3	214.5	50.2	31.6	97.00
C8-01	8434220374	1	8-UN	87.0	87.0	153	25	328.87	2193.020	30	137.1	270.5	65	41.5	127.00
	8434220375	1.125	8-UN	87.0	87.0	153	25	328.87	2193.020	30	134.0	270.5	65	41.5	127.00
C8-02	8434220376	1.25	8-UN	104.5	104.5	165	28	514.84	3433.170	30	142.8	286.5	82.5	50.15	135.00
	8434220377	1.375	8-UN	104.5	104.5	165	28	514.84	3433.170	30	139.6	286.5	82.5	50.15	135.00
C8-03	8434220378	1.5	8-UN	123.1	118.3	184.5	35	746.70	4979.300	30	155.9	321.5	90	59.1	150.50
	8434220379	1.625	8-UN	123.1	118.3	184.5	35	746.70	4979.300	30	152.8	321.5	90	59.1	150.50
C8-04	8434220380	1.75	8-UN	150.0	143.5	210.75	48	1177.31	7850.800	30	175.8	365.0	110	71.7	169.75
	8434220381	1.875	8-UN	150.0	143.5	210.75	48	1177.31	7850.800	30	172.7	365.0	110	71.7	169.75
	8434220382	2	8-UN	150.0	143.5	210.75	48	1177.31	7850.800	30	169.5	365.0	110	71.7	169.75
C8-05	8434220383	2.25	8-UN	182.5	174.3	235.75	59	1904.04	12696.940	30	188.1	393.0	136	87.1	179.75
	8434220384	2.5	8-UN	182.5	174.3	235.75	59	1904.04	12696.940	30	181.8	393.0	136	87.1	179.75
C8-06	8434220385	2.75	8-UN	210.0	210.0	259.75	65	2542.11	16951.840	30	199.4	432.0	163.5	105	199.75
	8434220386	3	8-UN	210.0	210.0	259.75	65	2542.11	16951.840	30	193.1	432.0	163.5	105	199.75
	8434220387	3.25	8-UN	258.1	258.1	302.8	85	4059.32	27069.190	30	229.8	492.6	204	129	232.25
C8-07	8434220388	3.5	8-UN	258.1	258.1	302.8	85	4059.32	27069.190	30	223.4	492.6	204	129	232.25
	8434220389	3.75	8-UN	258.1	258.1	302.8	85	4059.32	27069.190	30	217.1	492.6	204	129	232.25

Model	Ordering No.	Bolt Dia		Tool Dia	Side Dia	Tool Height	Radial Dim'n	Max Initial Bolt Load	Hyd Area mm ²	Ram Stroke	Extra Stud Length	Headroom Dimension	AF	Radial Dim'n	Dim'n
		D	Thread Pitch	A	F	B	C				G	E		H	J
		mm		mm	mm	mm	mm	mm	kN	mm	mm	mm	mm	mm	mm
C8-01	8434220390	24	3	87.0	87.0	153	25	328.87	2193.020	30	138	270	65	41.5	127.00
	8434220391	27	3	87.0	87.0	153	25	328.87	2193.020	30	135	270	65	41.5	127.00
	8434220392	30	3.5	87.0	87.0	153	25	328.87	2193.020	30	133.5	271.5	65	41.5	127.00
C8-02	8434220393	33	3.5	104.5	104.5	165	28	514.84	3433.170	30	142.5	287.5	82.5	50.15	135.00
	8434220394	36	4	104.5	104.5	165	28	514.84	3433.170	30	141	289	82.5	50.15	135.00
C8-03	8434220395	39	4	123.1	118.3	184.5	35	746.70	4979.300	30	157.5	324	90	59.1	150.50
	8434220396	42	4.5	123.1	118.3	184.5	35	746.70	4979.300	30	156	325.5	90	59.1	150.50
	8434220397	45	4.5	150.0	143.5	210.8	48	1177.31	7850.800	30	179.25	369	110	71.7	169.75
C8-04	8434220398	48	5	150.0	143.5	210.8	48	1177.31	7850.800	30	177.75	370.5	110	71.7	169.75
	8434220399	52	5	150.0	143.5	210.8	48	1177.31	7850.800	30	173.75	370.5	110	71.7	169.75
	8434220400	56	5.5	182.5	174.3	235.8	59	1904.04	12696.940	30	196.25	400	136	87.1	179.75
C8-05	8434220401	60	5.5	182.5	174.3	235.8	59	1904.04	12696.940	30	192.25	400	136	87.1	179.75
	8434220402	64	6	182.5	174.3	235.8	59	1904.04	12696.940	30	189.75	401.5	136	87.1	179.75
	8434220403	68	6	210.0	210.0	259.8	65	2542.11	16951.840	30	209.75	440.5	163.5	105	199.75
C8-06	8434220404	72	6	210.0	210.0	259.8	65	2542.11	16951.840	30	205.75	440.5	163.5	105	199.75
	8434220405	76	6	210.0	210.0	259.8	65	2542.11	16951.840	30	201.75	440.5	163.5	105	199.75
	8434220406	80	6	258.1	258.1	302.8	85	4059.32	27069.190	30	240.8	501.05	204	129	232.25
C8-07	8434220407	85	6	258.1	258.1	302.8	85	4059.32	27069.190	30	235.8	501.05	204	129	232.25
	8434220408	90	6	258.1	258.1	302.8	85	4059.32	27069.190	30	230.8	501.05	204	129	232.25
	8434220409	95	6	258.1	258.1	302.8	85	4059.32	27069.190	30	225.8	501.05	204	129	232.25

Compact 8 ordering numbers

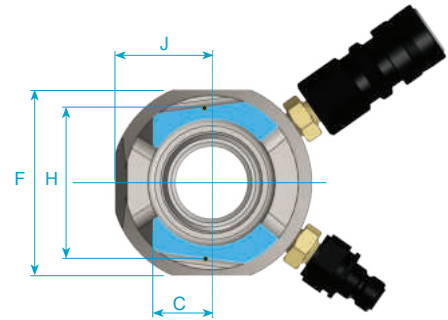
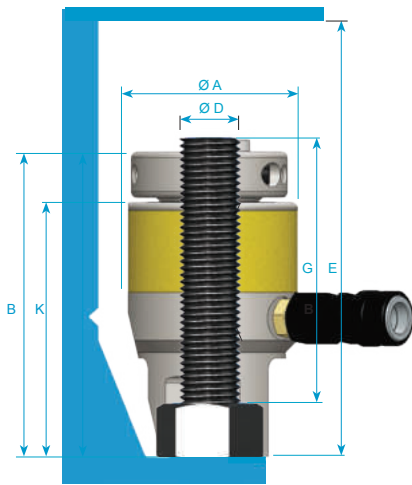

Technical Specification

Maximum Working Pressure = 1500bar : 21750psi
 Maximum ram stroke = (Tools 01 to 07): 30mm : 1.181"
 Maximum ram stroke = (Tool 00): 20mm : 0.787"

Tool No.	Load Cell Ordering No.	Imperial			Metric		
		Bolt D (inch)	Thread P	Imperial Ordering No.	Bolt D (inch)	Thread P	Metric Ordering No.
C8-00	8434220054	3/4"	UNC	8434220413	M20	2.5	8434220415
		7/8"	UNC	8434220414	M22	2.5	8434220416
C8-01	8434220055	1"	8-UN	8434220018	24	3	8434220020
		1 1/8"	8-UN	8434220019	27	3	8434220021
					30	3.5	8434220022
					33	3.5	8434220025
C8-02	8434220056	1 1/4"	8-UN	8434220023	36	4	8434220026
		1 3/8"	8-UN	8434220024	39	4	8434220029
C8-03	8434220057	1 1/2"	8-UN	8434220027	42	4.5	8434220030
		1 5/8"	8-UN	8434220028	45	4.5	8434220034
C8-04	8434220058	1 3/4"	8-UN	8434220031	48	5	8434220035
		1 7/8"	8-UN	8434220032	52	5	8434220036
		2"	8-UN	8434220033	56	5.5	8434220039
C8-05	8434220059	2 1/4"	8-UN	8434220037	60	5.5	8434220040
		2 1/2"	8-UN	8434220038	64	6	8434220041
C8-06	8434220060	2 3/4"	8-UN	8434220042	68	6	8434220044
		3"	8-UN	8434220043	72	6	8434220045
					76	6	8434220046
C8-07	8434220061	3 1/4"	8-UN	8434220047	80	6	8434220050
		3 1/2"	8-UN	8434220048	85	6	8434220051
		3 3/4"	8-UN	8434220049	90	6	8434220052
					95	6	8434220053

You can order Compact-8 tensioners using the table above. There are also many different configurations available for our Compact-8 subsea bolt tensioners.

WTB

Wind turbine bolt tensioner

Automatic reset

Internal heavy duty springs automatically resets the tensioner once the pressure has been released.

High life puller

The products are manufactured from aircraft quality high strength tensile steel and are compact and lightweight for ease of handling.



These feature-packed tensioners have been designed with rapid tensioning in mind and offer a safe, reliable and consistent method of simultaneously tensioning many bolts.

Fail safe technology

All of our WTB tensioners are fitted with fail safe technology , so in the eventuality of a breakage, it will fail safely in the tool.

Grip surface

For easy user handling.

Optional cycle counter

For maintenance scheduling purposes all Aero WTB Tools offer an optional mechanical pressure cycle counter.

Swivel connection

360° swivel operation allows the hydraulic hoses to be positioned in the best possible position to allow open access to the tensioning tools.

Geared nut run down

The inclusion of a gear nut run-down mechanism offers a very rapid and consistent way of seating the hexagon nuts during the tensioning procedure.

Best fit

The interchangeable profile cut spacer at the base of the tool gives the tensioner the flexibility to be used on many different applications.

“Snap Down” Nut Drive

To increase speed all Aero WTB tensioners are fitted with a spring loaded device that automatically engages the tensioner drive socket with the hexagon nut.



WTB technical data

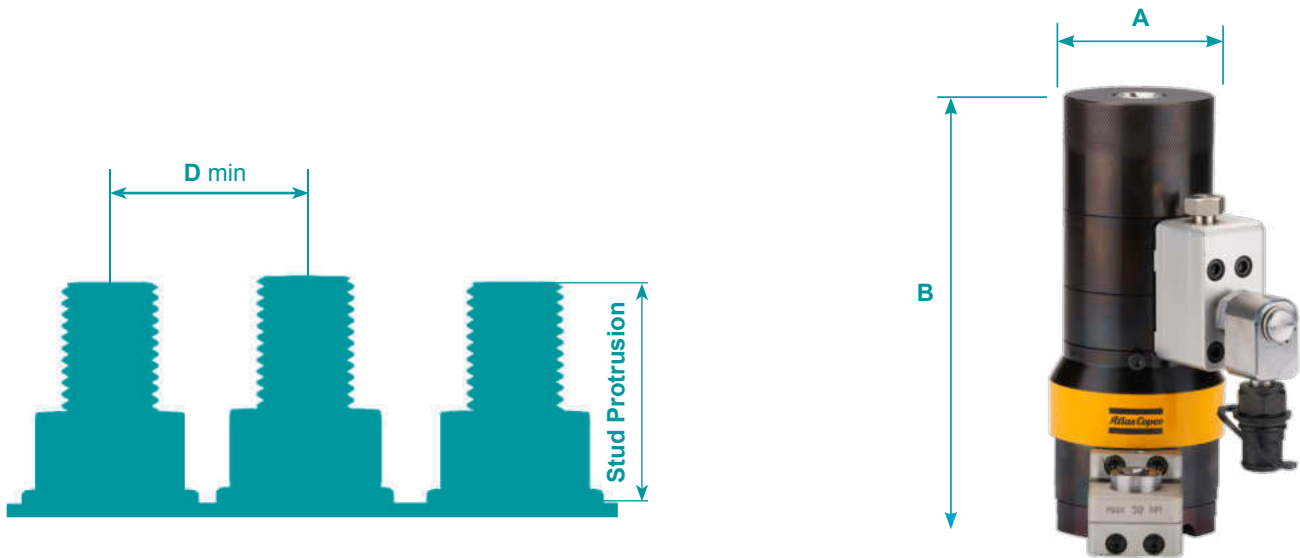

Ordering No.	Model	Bolt Diameter Metric	Stud Protrusion (Mm)		Max Stroke mm	Maximum Load		Hydraulic Pressure Area		Dia A mm	Height B mm	D mm	Weight kg
			min	max		kN	lbs	mm2	in2				
8434 2200 62	WTB30	M30	59	69	8	465.38	104622	3447.21	5.343	72	205	64	6.16
8434 2200 63	WTB33	M33	64	73	10	575.80	129444	4265.09	6.611	79	217.5	71	7.24
8434 2200 64	WTB36	M36	71	81	10	678.26	152478	5024.05	7.787	84.5	229.5	77	8.75
8434 2200 65	WTB39	M39	76	86	10	810.58	182225	6004.20	9.307	92	263	83	11.12
8434 2200 66	WTB42	M42	83	93	10	929.67	208999	6886.37	10.674	97	262.5	95	12.75
8434 2200 67	WTB45	M45	88	98	10	1079.48	242682	7996.12	12.394	105	275.5	94.5	15.86
8434 2200 68	WTB48	M48	94	104	10	1221.57	274620	9048.67	14.025	111	286.5	100.5	17.84
8434 2203 50	WTB56	M56	110	120	10	1686.19	379070	12490.29	19.359	132	314	115	26.5
8434 2203 51	WTB64	M64	124	134	10	2221.00	499300	16461.30	25.515	150	352	124	35

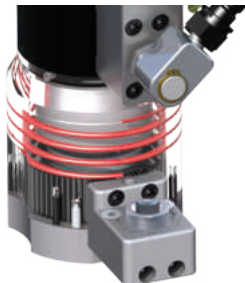

"Snap Down" Nut Drive



Automatic Reset



Best Fit

WTF customized foundation tensioner

Atlas Copco wind turbine foundation tensioning tools can be supplied to suit many different All Thread Bars and the more conventionally ISO metric and Imperial Unified thread forms. These feature packed tensioners have been designed with rapid tensioning in mind and offer a safe, reliable and consistent method to simultaneously tension many foundation bolts.

Seal reliability

Class leading high pressure seal technology.

Long piston stroke

The Aero WTF range of tensioners offer up to 25mm piston/ram stroke capability.

Swivel connection

360° swivel operation allows the hydraulic hoses to be positioned in the best possible position to allow open access to the tensioning tools.

Geared nut run down

The inclusion of a gear nut run-down mechanism offers a very rapid and consistent way of seating the hexagon nuts during the tensioning procedure.

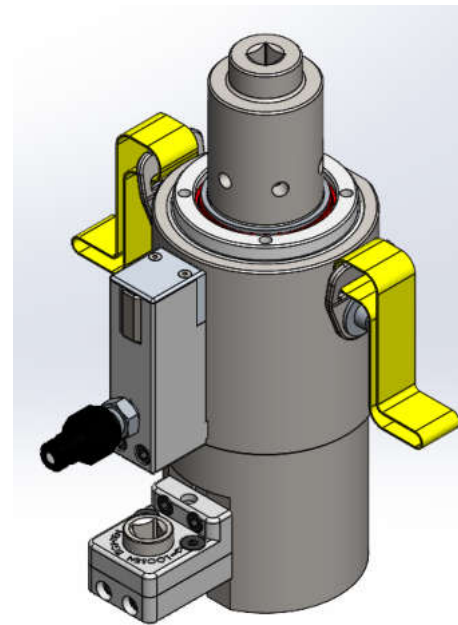

WTF Foundation tensioners come in four basic types.

- 1 Long piston stroke tensioner
- 2 Metric thread tensioner
- 3 Short piston stroke tensioner
- 4 Elliptical tensioner

All of our WTF foundation tensioners are made specifically for each customer. Please get in touch with our sales team for a quote.

SP1500

A smart powerpack for tensioning tools



Scan me to view the webpage!

The SP1500 powerpack is perfect for any tensioning tool, improving your overall tensioning process.

The bolt tensioning process can be a slower than others, however if you integrate the SP1500 tensioning powerpack into your processes - it can speed it up by upto 30%.

The SP1500 tensioning powerpack is a smart choice for tensioning operations with a perfect balance of speed and durability even in extreme weather conditions.

Smart Powerpack



SP1500

- Three stage
- Effective oil cooling system
- High strength steel frame
- Oil filter for enhanced life
- Class 1 gauge (+/- 1% full scale)
- Auto shutoff after 1 minute idling
- High temperature protection



A combination of high flow gear powerpack and high flow intensifier delivers a uniform speed over the entire pressure range, speeding up the process.



Remote pendant operation for pressure build up and pressure release, enables operator to stay away from high pressure areas.



High performance intensifier gives a smooth energy and efficient operation, with these features in place it achieves minimum wear and tear on all components.



Model	Current Supply			Oil flow <150 bar l/m	Oil flow @150 to 1500 bar l/m	Usable oil capacity		Max Pressure bar	Weight with oil		Height		Width		Length		Ordering No.
	Voltage	Frequency	Current			l	Gal		kg	Lb	mm	in	mm	in	mm	in	
SP1500-230	230 V	50 Hz	10 A	4.54	0.45	1.7	0.45	1500	40	88.2	410	16.1	275	10.8	590	23.2	8434 2203 68
SP1500-230-60	230 V	60 Hz	10 A	4.09	0.45	1.7	0.45	1500	40	88.2	410	16.1	275	10.8	590	23.2	8434 2203 67

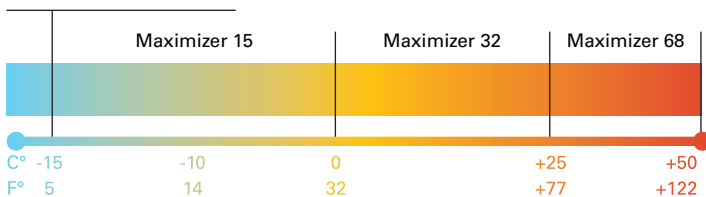

Accessories	Order number
4 port manifold kit (SP700)	8434 2040 50
Maximizer 15 Oil	8434 2040 51
Maximizer 32 Oil	8434 2200 02

Hydraulic tensioning powerpacks

Electric



		SP1500	SP1500	SP1500
Ordering Numbers		115V - 60Hz 8434 2203 66	230v - 50Hz 8434 2203 68	400v - 50Hz 8434 2203 70
Dimensions (Lx-WxH)	inches	16.1 x 10.8 x 23.2	17.3 x 12.6 x 16.5	17.3 x 13 x 17.3
	mm	410 x 275 x 590	460 x 320 x 420	440 x 330 x 440
Weight (w/o / with oil)	lb	88.2	61.6 / 70.4	64.9 / 73.7
	kg	40	28 / 32	29.5 / 33.5
Oil Capacity	Gallons	0.45	0.45	0.45
	Liters	1.7	1.7	1.7
Intercooler System		Yes	Yes	Yes
Auto Cycle		Yes	Yes	Yes
Ports		1	1	1

Air



		D500 (low)	D500 (High)	D600 (low)	D600 (High)	Airbac Powerpack
Ordering Numbers		8434 2200 05	8434 2200 06	8434 2202 62	8434 2202 63	4222 2601 06
Dimensions (Lx-WxH)	inches	17.7 x 16.5 x 16.5	17.7 x 16.5 x 16.5	23.6 x 16.5 x 16.5	23.6 x 16.5 x 16.5	20 x 14 x 13
	mm	450 x 420 x 420	450 x 420 x 420	600 x 420 x 420	600 x 420 x 420	513 x 355 x 340
Weight (w/o / with oil)	lb	49	49	58.4	58.4	22.5
	kg	22.5	22.5	26.5	26.5	10.24
Oil Capacity	Gallons				0.95	
	Liters	5	5	15	15	6.5
Ports		1	1	1	1	2

Hoses and oil not included with the powerpack. Be sure to order corresponding amount of oil for your powerpack and select hose length for your application.

Maintenance kits are available for every powerpack model. Consult your local Atlas Copco bolting representative for ordering information.

Accessories for bolt tensioners

Hand Powerpacks

Description	Ordering No.
Low Pressure Hand Powerpack	8434 2200 03
High Pressure Hand Powerpack	8434 2200 04



Hydraulic Hoses

Description	Ordering No.
4.Ply 1.3 Meter Long Hose (Low Pressure)	8434 2200 10
4.Ply 1.5 Meter Long Hose (Low Pressure)	8434 2200 11
4.Ply 3.0 Meter Long Hose (Low Pressure)	8434 2200 12
4.Ply 5 Meter Long Hose (Low Pressure)	8434 2200 13
6.Ply 1.3 Meter Long Hose (High Pressure)	8434 2200 14
6.Ply 1.5 Meter Long Hose (High Pressure)	8434 2200 15
6.Ply 3.0 Meter Long Hose (High Pressure)	8434 2200 16
6.Ply 5 Meter Long Hose (High Pressure)	8434 2200 17

1500 bar Hydraulic Link Hose



Couplers/Nipples

Description	Ordering No.
1/4" Male X 1/4" Male Adaptor (Tensioner)	4222 2700 19
1/4" Male X 1/4" Cejn Male (Hose)	4222 2700 20
1/4" Bonded Seal	4222 2700 21
C116 Female Coupling (Low Pressure)	4222 2700 22
C116 Male Nipple (Low Pressure)	4222 2700 23
C125 Female Coupling (High Pressure)	4222 2700 24
C125 Male Nipple (High Pressure)	4222 2700 25
1/4 BSP M X 1/8 BSP M ADAP	4222 2701 52
1/8" Bonded Seal	4222 2701 53
1/8" BSP CONED BLANK PLUG	4222 2701 54
9/16" UNF CONED BLANK PLUG	4222 2701 55
1/4" BSP BLANK PLUG	4222 2701 56



Hydraulic Oil

Description	Ordering No.
AWS68 - Hyd Oil One Gallon	8434 2200 01
AWS32 - Hyd Oil One Gallon	8434 2200 02

Type	Ordering No.
Tellus 46 5L	8434 2040 45
Maximizer 15	8434 2040 51
Maximizer 32	8434 2200 02
Maximizer 68	8434 2200 01



Hydraulic nuts

Top collar and bottom collar models

Bottom collar

Hydraulic Connections

User configurable quick release connections.
Side and top connections available.

Nut Body

Designed with considerable allowable piston movement.

Hydraulic Seals

Proven seal technology ensures thousands of tool pressure cycles.

Load retaining Collar

The tension is permanently retained by means of the load retaining collar.

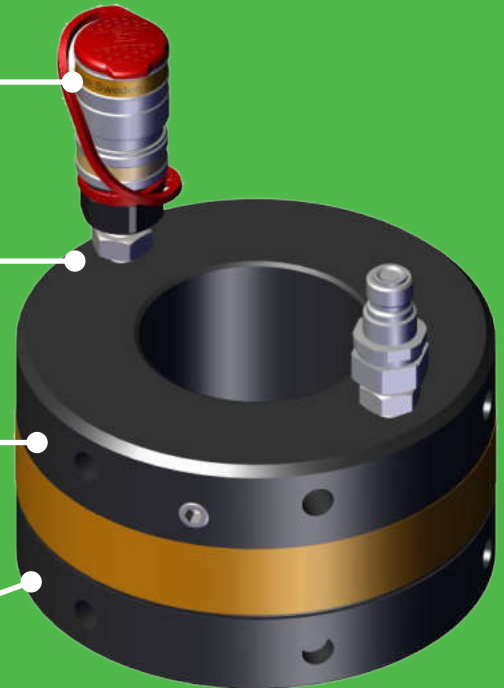

The hydraulic nut is completely customizable, and can be manufactured to any specific application.

Our knowledgeable and experienced team here at Atlas Copco will help guide you and create the perfect hydraulic nut solution that will suit your application.

Design and manufacturing is controlled fully in house ensuring the highest quality and shortest lead times. We always work to achieve the quickest turnaround times.

Hydraulic Nuts offer an extremely rapid and simple method of simultaneously accurately tensioning every bolt on a bolted joint. Hydraulic Nuts become a permanent part of the bolted joint and remain on the joint after the bolt load has been generated.

Top collar

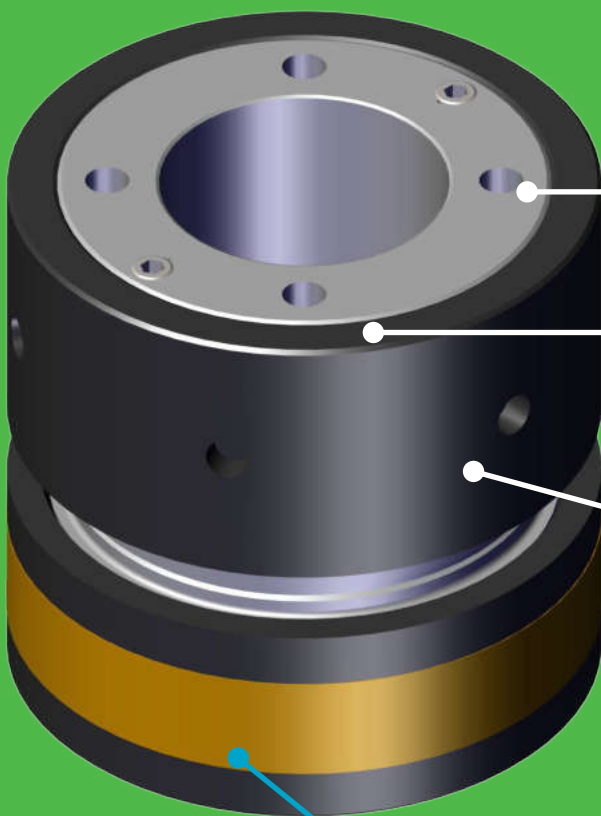

Hydraulic Connections
User configurable quick release connections.
Side and top connections available.

Load retaining Collar
Interfaces with load collar to retain bolt load.

Load retaining Collar
The tension is permanently retained by
means of the load retaining collar.

Nut Body
Designed with considerable allowable piston movement.

All of our Hydraulic Nuts are made specifically for each customer please get in touch with your local Atlas Copco representative for a quote.

Customized Solutions

Designed for your application



Reach out to your local representative for a customized solution for your application

From M4 to M720, there's nothing too big or small.

Atlas Copco's in-house development team can design, manufacture and assemble any custom tensioner design. No matter the application, our team can get it done. By providing us with basic measurements, we can create the exact tensioner design for your application.

All parts of a tensioner can be customized to cater for any special application. Common customizations requested can consist of to match thread pitch, bolt load requirements and nut rotating socket height.

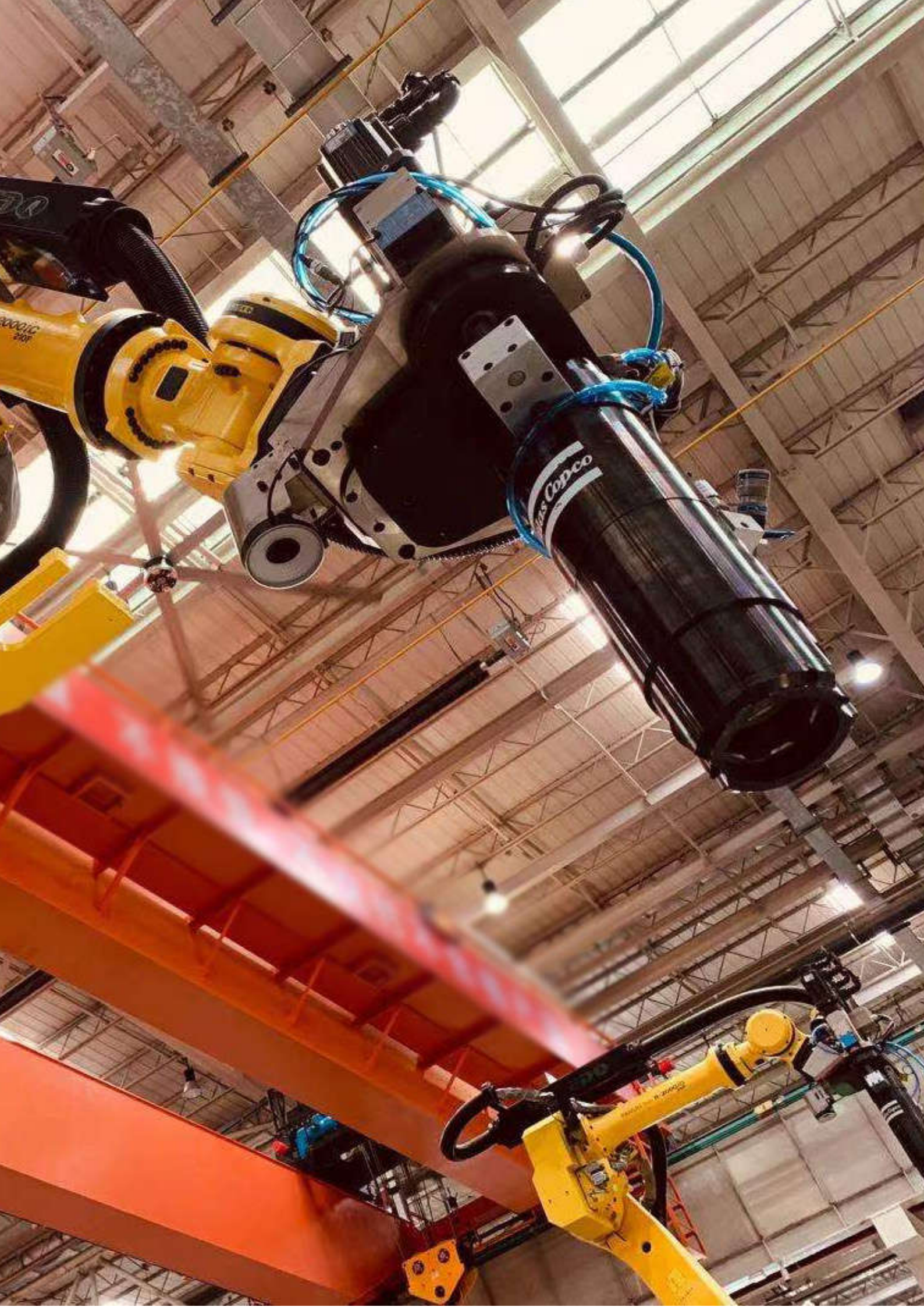

Direct Fit type tensioner

What is it?

Direct fit tensioners consist of a nut rotating socket, bridge and a threaded loadcell. Having the loadcell threaded means that an insert is not required on the application. This enables us to make the tensioner much smaller to fit difficult applications, as less components are required.

Key features

- Can design and manufacture to smaller sizes.
- Ideal for fitting on difficult to reach applications.

Typical Applications

- Low density polyethylene (LDPE) Plants.
- Crane slew rings.
- Crane Assembly.
- Flanges with reduced bolt circle diameter (BCD) or limited spaces.



Long Stroke Cylinder tensioner

What is it?

This is simply used as a pulling device more than a tensioner really, so it can be used for pulling heavy equipment. For example, like a rope attached to a steel bridge that needs to be pulled up.

Key features

- Air return or hydraulic return can be offered.
- Can be made to fit certain space restrictions.
- Different coating can be applied.

Typical Applications

- Pulling applications.
- Nets around oil rigs.
- Offshore buoyancy aids.



Monobloc type tensioner

What is it?

A monoblock tensioner consists of a single unit or "monoblock" that houses the hydraulic piston and the tensioning mechanism, which tensions two bolts simultaneously. The monoblock is typically smaller and more compact than other types of tensioners, which makes it ideal for use in tight spaces or in applications where access is restricted.

Key features

- Tension multiple bolts at once.
- Uniform tensioning on the joint.
- Bespoke design for specific applications

Typical Applications

- Engine blocs.
- Nuclear plant framework.
- G-clamp connectors.
- 2 bolts within close proximity that need larger loads.



Reaction Nut type tensioner

What is it?

The reaction nut type tensioner is designed to achieve and maintain the correct tension in bolts. There is a specialized nut or washer that is placed on the opposite side of the bolt from the fastening point.

Key features

- High load capacity.
- Accurate tensioning control.
- Ease of installation.
- Compatibility with bolt sizes.

Typical Applications

- Special thread on long stud protrusions.
- Wind foundation tools.
- Bridge construction.



Special Insert type tool

What is it?

Insert type tensioners generally consist of an NRS, bridge, load-cell and an insert. The benefit of an insert type tensioner is that you can potentially use the same loadcell on different studs by changing the insert.

Key features

- Use the same loadcell on different studs.
- Different thread type can be added.
- Different loads can be achieved.
- Different coating can be applied.
- Can have auto, hydraulic or spring return can be used.

Typical Applications

- Special threads.
- Tight restrictions, extreme loads.
- All engineering applications.
- Construction.
- Wind foundation.



Multi-stud type tensioner (MST)

What is it?

A multi-stud tensioner is a tool used to simultaneously tension multiple bolts or studs on a flange or other joint. It consists of a hydraulic cylinder that applies a stretching force to a set of bolts or studs, which helps to ensure that the clamping force is evenly distributed across the joint. They can help to reduce the time and labour required to tighten multiple bolts or studs.

Key features

- Quick installation with extreme accuracy.
- Tension multiple bolts at once.
- Uniform tensioning on the joint.
- Bespoke design for specific applications
- Reduces time on the application.

Typical Applications

- Steam generators.
- Nuclear Industry.



Robotic adaptable tensioners

What is it?

Robotic adaptable tensioners are designed to work with automated robotic systems, which can either be insert type or direct fit. They can be offered with QST Spindles or mounts, whichever is required for your application. These tensioners can save operator time and increase the overall accuracy of processes.

Key features

- Reduce operator fatigue.
- Reduce process times on the application.
- More accurate tightenings .

Typical Applications

- Wind turbine manufacture installations.
- Blade hubs.
- Engineering applications that have multi-stud tensioning.



Specialized Blade tensioner

What is it?

This type of tensioner is very similar to the WTB Tensioner where the design includes a puller bar. The puller bar type tensioners can also be included in Monoblock and MST. The puller bar component does exactly what its name insinuates, it pulls on the bolt stretching it until it meets the required load.

Key features

- Can be used on restrictive space envelopes.
- Different coats can be applied to the tensioner.
- Various threads can be manufactured.

Typical Applications

- Wind turbine blades.
- Slew cranes.
- Foundation.



Flange spreaders

Mechanical spreading wedges

Portable and lightweight

360 degree rotation handle design

No finger pinching points

Rugged carbon steel construction



ACMP700 Features

- Lightweight and easy to handle
- Sealed bladder
- Can be used at any angle and orientation
- Highly resistant to oil leakage

ACMP700

- Overall Length: 554.0mm (21.81")
- Handle Length: 360.0mm (14.17")
- Powerpack Weight: 4.0Kg (8.8lb)





ACMS08T features

- Portable and lightweight
- 360 degree rotation handle design
- No finger pinching points
- Rugged carbon steel construction

Capabilities

8T spreading force from
180Nm (133ft.lb) of torque

Spreads: 6.0mm – 63.7mm
(0.24" - 2.5")
(without stepped blocks)

Spreads: 60.0mm – 86.7mm
(2.4" - 3.4")
(with stepped blocks)

(0.24" - 1.28") spread using only 1st step



ACHS14T features

- High power to weight ratio
- Revolving handle
- No finger pinching points

Capabilities

14T spread force from
10,000psi (700 Bar) Hydraulic pressure

Spreads: 6.0mm – 63.7mm
(0.24" - 2.5")
(without stepped blocks)

Spreads: 60.0mm – 86.7mm
(2.4" - 3.4")
(with stepped blocks)

Kit contents

- 1 x ACMS08T wedgehead
- 1 x 203 N m (150 ft lb) torque wrench with 22 mm socket
- 1 x Safety block
- 2 x Step blocks
- 2 x Screws for step block
- 1 x Lanyard
- 1 x Allen key
- 1 x Instruction manual
- 1 x Polycarbonate carrying case

Kit contents

- 1 x ACHS14T wedgehead c/w hydraulic cylinder
- 1 x Lanyard
- 1 x Allen key
- 1 x Safety block
- 2 x Step block
- 2 x Screws for step blocks
- 1 x Instruction manual
- 1 x Polycarbonate carrying case

Part No.	Product	Description
8434 2058 04	Hydraulic Powerpack	ACMP700 Manual
8434 2058 05	Flange Spreader	ACMS08T Mechanical
8434 2058 06	Flange Spreader	ACHS14T Hydraulic
8434 2058 07	Hose Kit	Single Line 700 bar 4mtr

Nut splitters

Used to remove corroded and seized nuts



Bolt Size	1/2"		9/16"		5/8"		3/4"		7/8"		1"	
	Heavy	Standard	Heavy	Standard	Heavy	Standard	Heavy	Standard	Heavy	Standard	Heavy	
Nut Size A/F	22.2mm (7/8")	22.2mm (7/8")	23.8mm (15/16")	23.8mm (15/16")	27mm (1 1/16")	28.6mm (1 1/8")	31.8mm (1 1/4")	33.3mm (1 5/16")	36.5mm (1 7/16")	38.1mm (1 1/2")	41.3mm (1 5/8")	
Tool	ACNS12	ACNS12	ACNS12/ ACNS15	ACNS12/ACNS15		ACNS15		ACNS15	ACNS15	ACNS15/ ACNS20	ACNS20	

1 1/8"		1 1/4"		1 3/8"		1 1/2"		1 5/8"		1 3/4"	
Standard	Heavy	Standard	Heavy	Standard	Heavy	Standard	Heavy	Standard	Heavy	Standard	Heavy
42.9mm (1 11/16")	46mm (1 13/16")	47.6mm (1 7/8")	50.8mm (2")	52.4mm (2 1/16")	55.6mm (2 3/16")	57.2mm (2 1/4")	60.3mm (2 3/8")	61.9mm (2 7/16")	65.1mm (2 9/16")	66.7mm (2 5/8")	69.9mm (2 3/4")
ACNS20	ACNS20/ ACNS36	ACNS36	ACNS36	ACNS36		ACNS36		ACNS36	ACNS36/ ACNS50	ACNS50	

The combination of the sharp cutting tip and opposing convex reaction point encourages more efficient splitting by spreading the nut open rather than squashing the nut onto the stud. This makes it easier to rotate the nut for the second cut

- A Five models
(22-75 mm A/F)
- B Non standard range to cover up to 115 mm A/F
- C Compact design to work on flanges
- D Easy to change blade
- E Ergonomically designed

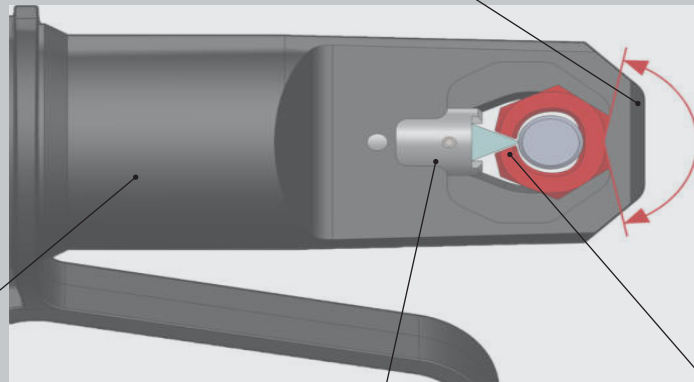

Integral hydraulic cylinder with high grade material to make it smallest and lightest nut splitter

Quick and easy cutting tip replacement

Cutting tip made from heat-treated shock-resisting tool steel for better cut and longer life

1 7/8"		2"	
Standard	Heavy	Standard	Heavy
71.4mm (2 13/16")	74.6mm (2 15/16")	76.2mm (3")	79.4mm (3 1/8")
ACNS50		ACNS50	ACNS50

Bolt Size	M14	M16	M20	M24	M30	M36	M42	M48
	Standard	Standard	Standard	Standard	Standard	Standard	Standard	Standard
Nut Size A/F	21mm (0.83")	24mm (0.94")	30mm (1.2")	36mm (1.4")	46mm (1.8")	55mm (2.2")	65mm (2.6")	75mm (3.0")
Tool	ACNS12	ACNS12/ ACNS15	ACNS15	ACNS15/ ACNS20	ACNS20	ACNS36	ACNS36/ ACNS50	ACNS50



Spatial envelope

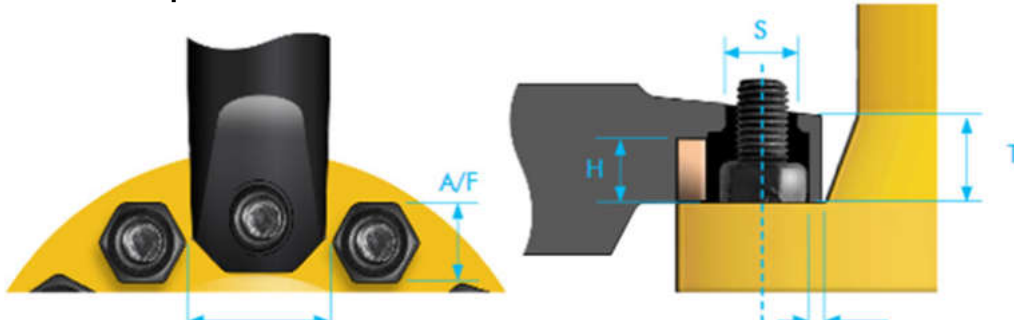

Symbol	Measurement	ACNS12		ACNS15		ACNS20		ACNS36		ACNS50	
		Min	Max	Min	Max	Min	Max	Min	Max	Min	Max
A/F	Across Flats	17.5 mm (0.69")	30.0 mm (1.18")	23.0 mm (0.91")	36.5 mm (1.44")	32.0 mm (1.26")	51.0 mm (2.01")	50.8mm (2.0")	65mm (2.6")	50.8mm (2.0")	80mm (3.15")
W	Clear Width	53.5 mm (2.11")	-	57.0 mm (2.24")	-	83.5 mm (3.29")	-	107.6mm (4.2")	-	107.6mm (4.2")	135mm (5.31")
S	Stud Diameter	-	24.5 mm (0.96")	-	25.5 mm (1.00")	-	38.0 mm (1.50")	-	49.2mm (1.94")	-	61mm (2.4")
H	Cutting height	-	20.0 mm (0.79")	-	22.0 mm (0.87")	-	31.5 mm (1.24")	-	45.5mm (1.8")	-	54.5mm (2.15")
N	Nose clearance	8.5 mm (0.33")	-	9.0 mm (0.35")	-	16.0 mm (0.63")	-	10.5mm (0.4")	-	10.5mm (0.4")	27mm (1.06")
T	Nose height	26.5 mm (1.04")		32.5 mm (1.28")		45 mm (1.77")		56mm (2.2")		65mm (2.56")	

Ordering No.	Our Model	Weight		Nut Range A/F	
		Kg	Lbs	MM	Inch
8434 2058 00	ACNS12	4	8.8	17.5 mm - 30.0 mm	(0.69" - 1.18")
8434 2058 01	ACNS15	4.5	9.9	23.0 mm - 36.5 mm	(0.91" - 1.44")
8434 2058 02	ACNS20	7	15.4	32.0 mm - 51.0 mm	(1.26" - 2.01")
8434 2058 03	ACNS36	11	24.2	50.8 mm - 65.0 mm	(2.00" - 2.56")
8434 2058 11	ACNS50	24.5	54	65 mm - 75.0 mm	(2.56" - 2.94")

Software

Solutions to optimize planning, process and performance for your applications.

2

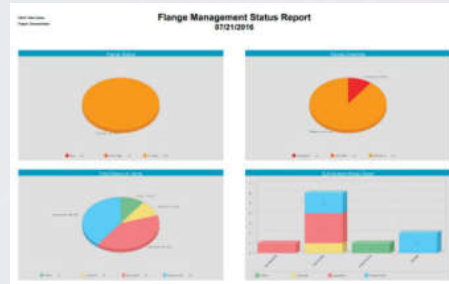

IFMS - Plan your jobs to ensure they will be completed correctly.

1



Bolt Load Software - Help you understand which tools are needed for the job.



Scan me, and request the Bolt Load Software for free



All of our software is available to use in conjunction with our tools, if you are interested in integrating these softwares into your process, reach out to your local Atlas Copco sales representative

3

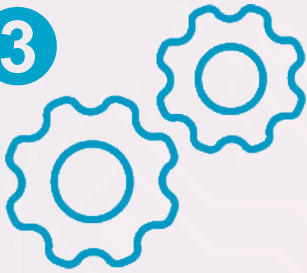

SQS - Guide yourself and other operators through any process, so all procedures are followed.

4

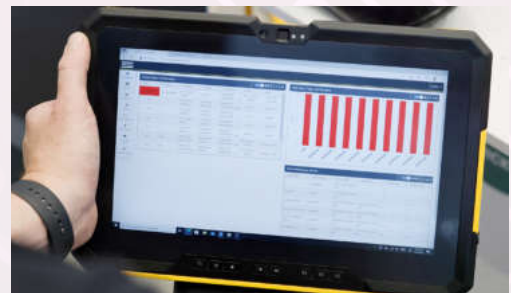

Toolsnet - See and store your data to ensure jobs have been completed correctly and get insights for improvements.



1 Bolt load software

Understand the tools you need for the job

Bolt Tightening Software & IOS/ Android APP

Software to complement our other standard tension and torque tightening products. This is now also available to install on IOS and Android platforms allowing users even easier access to critical calculations and bolt tightening procedures. The software includes data for the following standard flanges:

- ANSI B16.5
- ANSI B16.47 Series A
- MSS SP-44
- API 6A
- API 17SV
- Vector SPO Compact Flanges
- Norsok L-005

Contact your local Atlas Copco sales representative for more details to download and use the software or

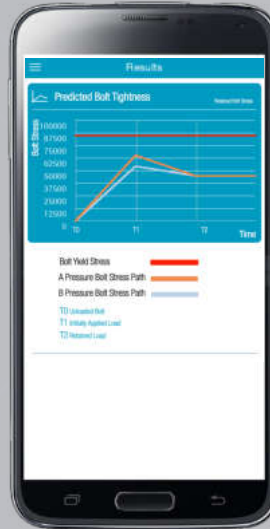
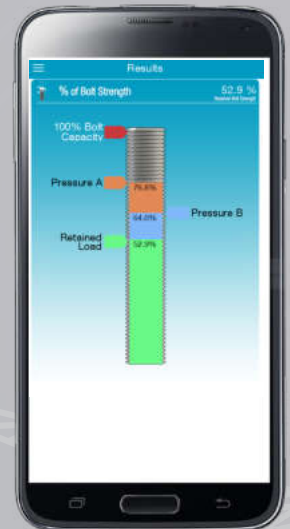
2 iFMS

Flange Management System

What is iFMS?

iFMS is used for the planning, data capture, analysis & reporting of activities related to the inspection, maintenance & testing of bolted joints and pipework.

Who is iFMS for?

Operators wishing to manage their assets throughout construction, commissioning, shutdowns, turnarounds and routine maintenance

- Service companies offering integrated flange management and pressure testing services.
- Specialist technical services companies providing flange management as a complementary service line.
- Construction companies required to produce and maintain auditable records for flange assembly and tightening activities.
- Engineering companies providing a specialist quality control function where state of the art software is a vital component of an overall flange management system.

What does it do?

- Flexible and customizable import routines allow data import from a variety of formats and applications.
- Flange management information capture and reporting based on Energy institute 'Guidelines for the management of integrity of bolted joints for pressurised systems'.
- System generated leak test packs are based on HSE 'Safety requirements for pressure testing Guidance Note GS4'.
- Software is easily customised to capture any data and generate additional service line work-packs.
- Drawing module allows PDF-based ISOs and P&IDs to be marked up to support Flange Management and Leak testing instructions, procedures and activities.
- Drawings and work-packs can be copied and edited, drawings up rev'd retaining mark-up to facilitate the rapid generation of packs.
- Customisable reports and outputs.
- Anomaly tracking.
- In built tools to monitor project progress.



What are the benefits?

- Ease of data import and system population.
- Established database of flange and connector types, gasket types, bolt materials.
- Can incorporate the torque and tension tool details from any supplier.
- The drawing views and the flange registers are always synchronised allowing users to work in whichever environment is most familiar.
- The real time data capture using handhelds support a more detailed and accurate audit trail as well as eliminating the time and errors associated with data re-keying.
- The software can be easily customised to support the functionality, data and branding to suit each client and project.
- iFMS can be made interoperable with existing business and engineering systems.
- Single database of drawings is reusable for all current & future FM and pressure testing activities eliminating time and costs associated with pre-engineering.
- iFMS is easily tailored to support additional service lines so can be used as a single tool to support your main business operations.
- Improves data integrity, eliminating costs associated with user errors.
- The iFMS engine has been used to drive major new-build, upgrade and shutdown projects globally.

③ SQS

Understand the tools you need for the job

Scalable Quality Solution

The Scalable Quality Solution 3 is a comprehensive software solution driving quality, process reliability, transparency as well as product safety. This error proofing software helps to achieve zero defects and to reduce costs of rework, scrap or warranty claims. The advent of Industry 4.0 brings rapid changes and new challenges. With our Smart Connected Assembly concept, which combines software, hardware and smart accessories, you maintain quality control in complex production systems and increase uptime in production for critical operations.

From stand-alone station to complete in the field

The Scalable Quality Solution 3 (SQS3) eliminates errors in tensioning/torque processes regardless of whether you start with a single station, a single job or whether you want to manage the process of your entire operation. Up to 10 stations can be connected, even different products or variations of products. SQS3 ensures product quality, process reliability and transparency as well as product safety at each station. It guides your operators through the assembly process leaving no room for error or oversight.



Your benefits

- Step-by-step visual operator guidance as well as part and tool verification minimize defects.
- Target zero defect through rework ability.
- Save money with less need for rework.
- Improved productivity with lower production costs.
- Save time by using our remote centralized configuration.
- Greatly reduces training time for new operators.
- Easy configuration to update process change and new product introduction.

4 Toolsnet

Analyze your data and optimize processes

What is toolsnet?

ToolsNet 8 provides data collection for our smart bolting tools; PFXC, SRBHA and STS or any of our range of intelligent tools. Other vendors can also report ToolsNet using Open Protocol.

The ToolsNet 8 dashboard is modular giving you a direct overview of the production in the plant. Extracting and visualizing the information you find most interesting and important to monitor – any time. Every user can configure the dashboard in a way that best suits their needs. Tightening systems from different vendors can also report to ToolsNet using Open

Top NOK applications
Shows the applications with the highest failure rate for a configured part of the tool structure.

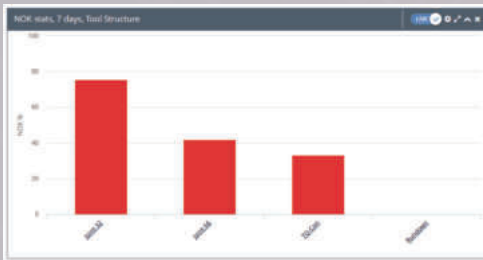

Running SPC
Shows the real-time X-bar and range charts for a configured application.



Tool maintenance
Shows all the tools that need service or calibration.

Model type	Serial number	Service date	Calibration date
B	9423185	2/24/2014 12:00:00 AM	1/1/1999 12:00:00 AM
B	484184	1/21/2004 12:00:00 AM	1/1/1999 12:00:00 AM
B	829117	7/21/2008 12:00:00 AM	1/1/1999 12:12:00 AM
BTV STB1 4810	4886044	9/9/2011 12:00:00 AM	1/1/1999 12:27:00 AM
BTV STB1 4810	9321422	1/1/1999 12:47:22 AM	1/1/1999 12:47:12 AM
B	722094	9/9/2008 12:00:00 AM	10/18/2008 3:02:00 PM
B	927046	8/18/2009 12:00:00 AM	7/24/2006 9:21:00 AM
B	874821	11/29/2008 12:00:00 AM	11/29/2008 11:01:00 AM
B	642265	6/7/2006 12:00:00 AM	9/29/2007 9:43:00 PM
B	643743	7/9/2008 12:00:00 AM	1/29/2010 12:24:00 PM

Latest results
Shows an overview of the latest results from the chosen part of the tool structure.

Status	Unit	Program	Result time	Torque	Angle
NOK	Final assembly	joint 06	6/12/2013 9:54:11 AM	15.21 Npm	48.00 Low
NOK	Final assembly	joint 32	6/12/2013 9:54:04 AM	25.75 Npm	136.00 Low
OK	Final assembly	joint 06	6/12/2013 9:54:01 AM	13.77 OK	56.00 OK
NOK	Final assembly	joint 32	6/12/2013 9:53:58 AM	21.67 OK	146.00 Low
OK	Final assembly	joint 06	6/12/2013 9:53:51 AM	11.05 OK	39.00 OK
OK	Final assembly	joint 32	6/12/2013 9:53:46 AM	20.74 OK	168.00 OK
NOK	Final assembly	joint 06	6/12/2013 9:53:41 AM	13.43 OK	63.00 Low
NOK	Final assembly	joint 32	6/12/2013 9:53:34 AM	17.96 Low	154.00 OK
NOK	Final assembly	joint 06	6/12/2013 9:53:31 AM	15.21 Npm	52.00 OK
NOK	Final assembly	joint 32	6/12/2013 9:53:29 AM	22.21 Npm	152.00 OK

ToolsNet 8 will:

- Boost your productivity with reduced rework and less bottlenecks.
- Improve your quality by avoiding recalls tracking changes and finding the problems before they occur.
- Reduce service costs with preventive maintenance for your tools, reduced down time and faster reaction time with alert notices.

Get in touch with your Atlas Copco contact today.

Learn more on www.atlascopco.com



Atlas Copco AB

(publ) SE-105 23 Stockholm, Sweden

Phone: +46 8 743 80 00

Reg. no: 556014-2720

atlascopco.com